

Tutorial for Creating Device Models in CAE Tool CadSoft EAGLE

Doc. Version 2011-08-13-1.2

Abstract: Tutorial for handling the EAGLE¹ library to create customized device models used in the schematics and layout editor. Guideline for extracting relevant information from the datasheet all the way down to useful schematic symbols and device packages. The example used is a power supply protection IC made by Linear Technology Corp.² - the LT4356.

Keywords: datasheet, symbol, package, device, variant, technology, pin, pin direction, pad, exposed pad, smd, solder stop, pitch, layer, grid, metric, imperial, inch, mil, DFN, MSOP, SO, BGA, prototyping, prototype, thermals, thermal bridge, solder stop mask, solder cream, export, BOM, bill of material

Introduction

This document aims to give electronics design engineers a tutorial on how to create custom specific device models using the CAE tool *EAGLE* (version 5.x) made by the German company *CadSoft Computer GmbH*. Especially in the prototyping phase, engineers tight on time who are in need to get a useful PCB layout ready for production within a few days make use of this tool.

The capabilities of the device library are in the scope of this tutorial using the *LT4356* with its electrical and mechanical shipment options as an example.

Special thanks to Linear Technology Corporation for the *LT4356* datasheet used within this document. Please visit *Linear Technology Corp.* at www.linear.com .



1 EAGLE is a registered trademark of CadSoft Computer GmbH.

2 Linear Technology is a registered trademark of Linear Technology Corporation.

Contents

1 The Target Device Model.....	3
1.1 Monolithic Block Symbol.....	3
1.2 Splitting the IC Symbol.....	3
1.3 Package related.....	5
1.4 Device Code related.....	6
1.5 The LT4356 within the Library.....	7
2 Workflow.....	9
2.1 Creating a new empty Library.....	10
2.2 Symbol Editing.....	11
2.2.1 The MAIN symbol.....	11
2.2.2 The AMP symbol.....	12
2.2.3 Drawing the MAIN Symbols.....	16
2.3 Package Editing.....	18
2.3.1 The DFN package.....	18
2.3.2 The SO package.....	27
2.3.3 The MSOP package.....	29
2.4 Device Editing.....	30
2.4.1 The DE-Version.....	30
2.4.1.1 Symbols.....	31
2.4.1.2 Package.....	35
2.4.1.3 Connecting Symbols with Package.....	36
2.4.1.4 Prefix.....	38
2.4.1.5 Value.....	38
2.4.1.6 Technologies.....	38
2.4.1.7 Attributes.....	39
2.4.1.7.1 Company Internal Part/Device Codes.....	41
2.4.1.8 Device Description.....	42
2.4.1.9 Make the library known to EAGLE.....	43
2.4.2 The MS-Version.....	45
2.4.3 The SO version.....	47
2.5 Library Description.....	48
2.6 Deleting, Renaming and Copying Symbols, Packages and Devices.....	49
2.6.1 Removing.....	49
2.6.2 Renaming.....	50
2.6.3 Copying.....	51
3 BOM Exporting.....	52
4 Useful Links.....	53
5 Disclaimer.....	53

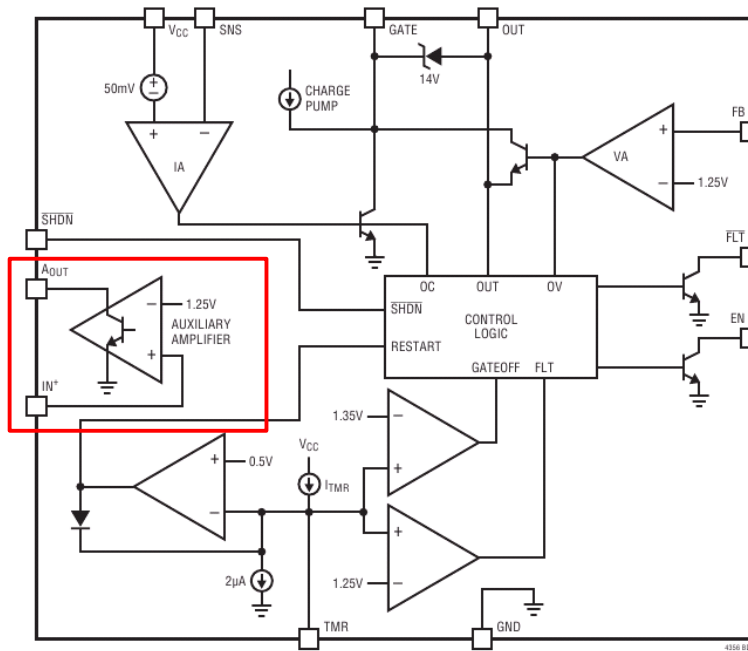
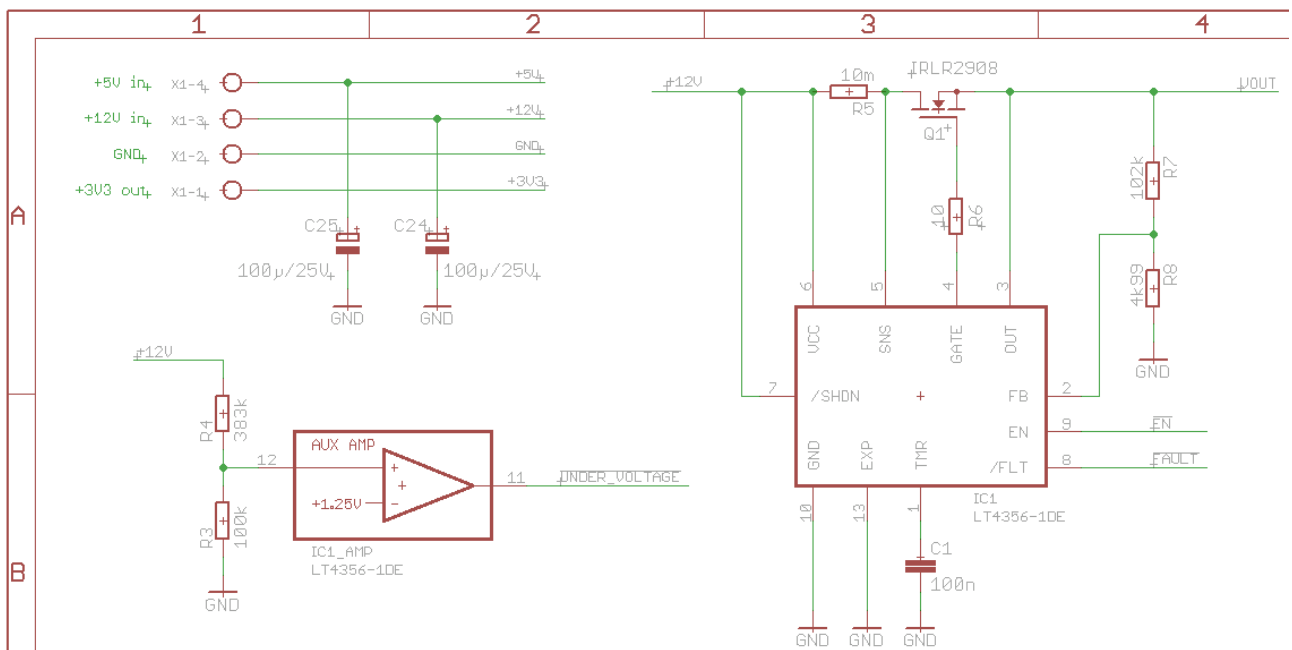

Figure 2: Block Diagram



Drawing 1: The LT4356 divided into two blocks

1.3 Package related

Figure 3 depicts the packages the IC is shipped in. Later, after doing the package setup in the library there will be three different packages available for the *LT4356*: the DFN12, MSOP10 and SO16. To distinguish the package versions, *EAGLE* uses the term **variant**. The red marked texts in Figure 3 will serve as variant name later in the device editor (section 2.4 page 30).

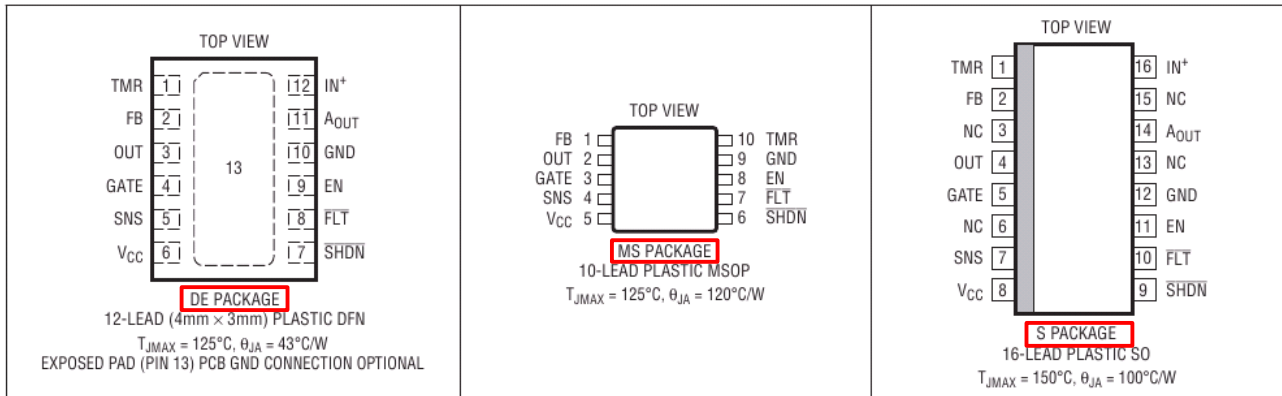

Figure 3: LT4356 Package Options

1.4 Device Code related

The manufacturer usually provides a table (see Table 1) that gives the device options available. The ordering code is framed in red. This table may inspire the *EAGLE* user of possible device names later in the device editor (section 2.4 page 30).

LEAD FREE FINISH	TAPE AND REEL	PART MARKING*	PACKAGE DESCRIPTION	TEMPERATURE RANGE
LT4356CDE-1#PBF	LT4356CDE-1#TRPBF	43561	12-Lead (4mm × 3mm) Plastic DFN	0°C to 70°C
LT4356IDE-1#PBF	LT4356IDE-1#TRPBF	43561	12-Lead (4mm × 3mm) Plastic DFN	-40°C to 85°C
LT4356HDE-1#PBF	LT4356HDE-1#TRPBF	43561	12-Lead (4mm × 3mm) Plastic DFN	-40°C to 125°C
LT4356CDE-2#PBF	LT4356CDE-2#TRPBF	43562	12-Lead (4mm × 3mm) Plastic DFN	0°C to 70°C
LT4356IDE-2#PBF	LT4356IDE-2#TRPBF	43562	12-Lead (4mm × 3mm) Plastic DFN	-40°C to 85°C
LT4356HDE-2#PBF	LT4356HDE-2#TRPBF	43562	12-Lead (4mm × 3mm) Plastic DFN	-40°C to 125°C
LT4356CMS-1#PBF	LT4356CMS-1#TRPBF	LTCNS	10-Lead Plastic MSOP	0°C to 70°C
LT4356IMS-1#PBF	LT4356IMS-1#TRPBF	LTCNS	10-Lead Plastic MSOP	-40°C to 85°C
LT4356HMS-1#PBF	LT4356HMS-1#TRPBF	LTCNS	10-Lead Plastic MSOP	-40°C to 125°C
LT4356CS-1#PBF	LT4356CS-1#TRPBF	LT4356S-1	16-Lead Plastic SO	0°C to 70°C
LT4356IS-1#PBF	LT4356IS-1#TRPBF	LT4356S-1	16-Lead Plastic SO	-40°C to 85°C
LT4356HS-1#PBF	LT4356HS-1#TRPBF	LT4356S-1	16-Lead Plastic SO	-40°C to 125°C
LT4356CS-2#PBF	LT4356CS-2#TRPBF	LT4356S-2	16-Lead Plastic SO	0°C to 70°C
LT4356IS-2#PBF	LT4356IS-2#TRPBF	LT4356S-2	16-Lead Plastic SO	-40°C to 85°C
LT4356HS-2#PBF	LT4356HS-2#TRPBF	LT4356S-2	16-Lead Plastic SO	-40°C to 125°C
LEAD BASED FINISH	TAPE AND REEL	PART MARKING*	PACKAGE DESCRIPTION	TEMPERATURE RANGE
LT4356CDE-1	LT4356CDE-1#TR	43561	12-Lead (4mm × 3mm) Plastic DFN	0°C to 70°C
LT4356IDE-1	LT4356IDE-1#TR	43561	12-Lead (4mm × 3mm) Plastic DFN	-40°C to 85°C
LT4356HDE-1	LT4356HDE-1#TR	43561	12-Lead (4mm × 3mm) Plastic DFN	-40°C to 125°C
LT4356CDE-2	LT4356CDE-2#TR	43562	12-Lead (4mm × 3mm) Plastic DFN	0°C to 70°C
LT4356IDE-2	LT4356IDE-2#TR	43562	12-Lead (4mm × 3mm) Plastic DFN	-40°C to 85°C
LT4356HDE-2	LT4356HDE-2#TR	43562	12-Lead (4mm × 3mm) Plastic DFN	-40°C to 125°C
LT4356CMS-1	LT4356CMS-1#TR	LTCNS	10-Lead Plastic MSOP	0°C to 70°C
LT4356IMS-1	LT4356IMS-1#TR	LTCNS	10-Lead Plastic MSOP	-40°C to 85°C
LT4356HMS-1	LT4356HMS-1#TR	LTCNS	10-Lead Plastic MSOP	-40°C to 125°C
LT4356CS-1	LT4356CS-1#TR	LT4356S-1	16-Lead Plastic SO	0°C to 70°C
LT4356IS-1	LT4356CS-1#TR	LT4356S-1	16-Lead Plastic SO	-40°C to 85°C
LT4356HS-1	LT4356HS-1#TR	LT4356S-1	16-Lead Plastic SO	-40°C to 125°C
LT4356CS-2	LT4356CS-2#TR	LT4356S-2	16-Lead Plastic SO	0°C to 70°C
LT4356IS-2	LT4356IS-2#TR	LT4356S-2	16-Lead Plastic SO	-40°C to 85°C
LT4356HS-2	LT4356HS-2#TR	LT4356S-2	16-Lead Plastic SO	-40°C to 125°C

Consult LTC Marketing for parts specified with wider operating temperature ranges. *The temperature grade is identified by a label on the shipping container.

Table 1: Order Information

Example: The term LT4356CDE-1 stands for the 12-lead (4mm x 3mm) plastic DFN version with commercial temperature range 0°C to 70°C:

LT4356 C DE - 1 options	Green → temperature range red → package blue → electrical version
--	---

Later the **device** name will be a generic term **LT4356-*** that has a wildcard (asterisk) which stands for the electrical version #1 or #2. *EAGLE* uses for the electrical version the term **technology**. Using wildcards in the device name is **not** mandatory but gives flexibility.

So the electrical version – the technology – as well as the package will be coded in the device name whereas the temperature range will become an **attribute** (see section 2.4.1.7 page 39).

1.5 The LT4356 within the Library

After all, the library we want to create shall appear in its structure in the *EAGLE* control panel as marked red on Image 1 - the outcome of our work. On the left you see the structure, on the right you get a preview of its elements.

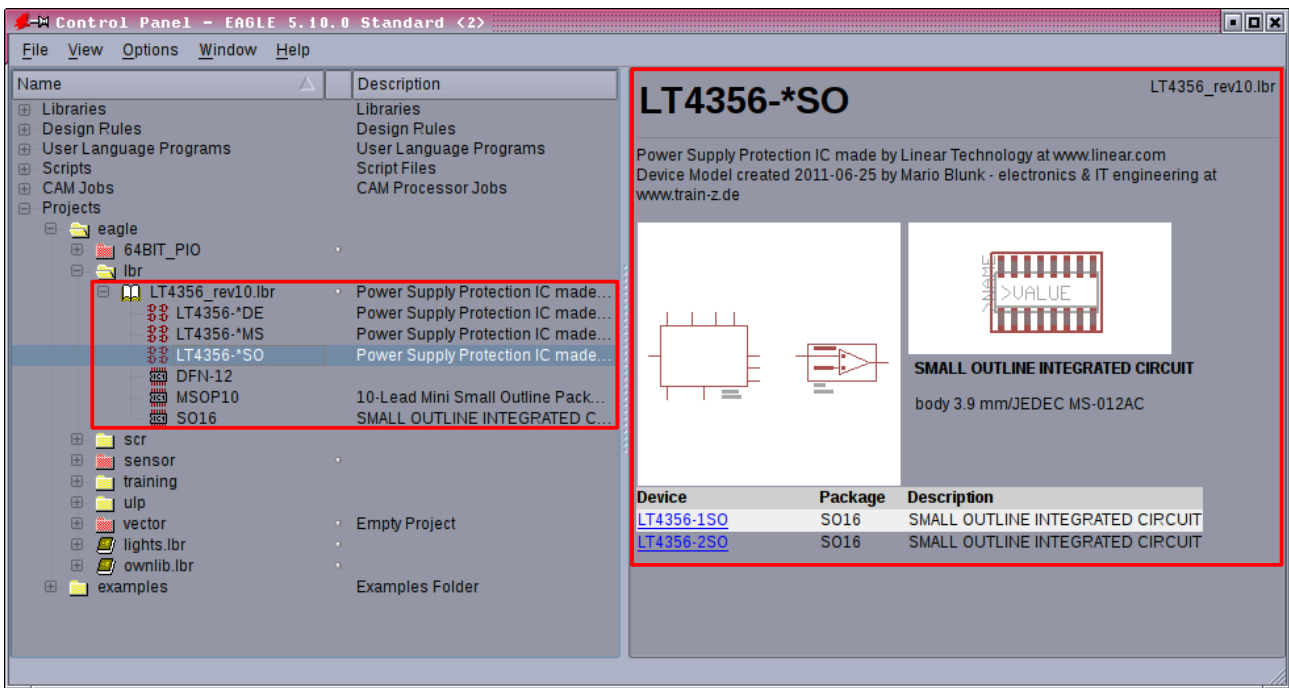

Image 1: Library Structure and Preview from the Control Panel

From the schematic editor, when fetching a device using the add command, the library contents are to appear as on Image 2.

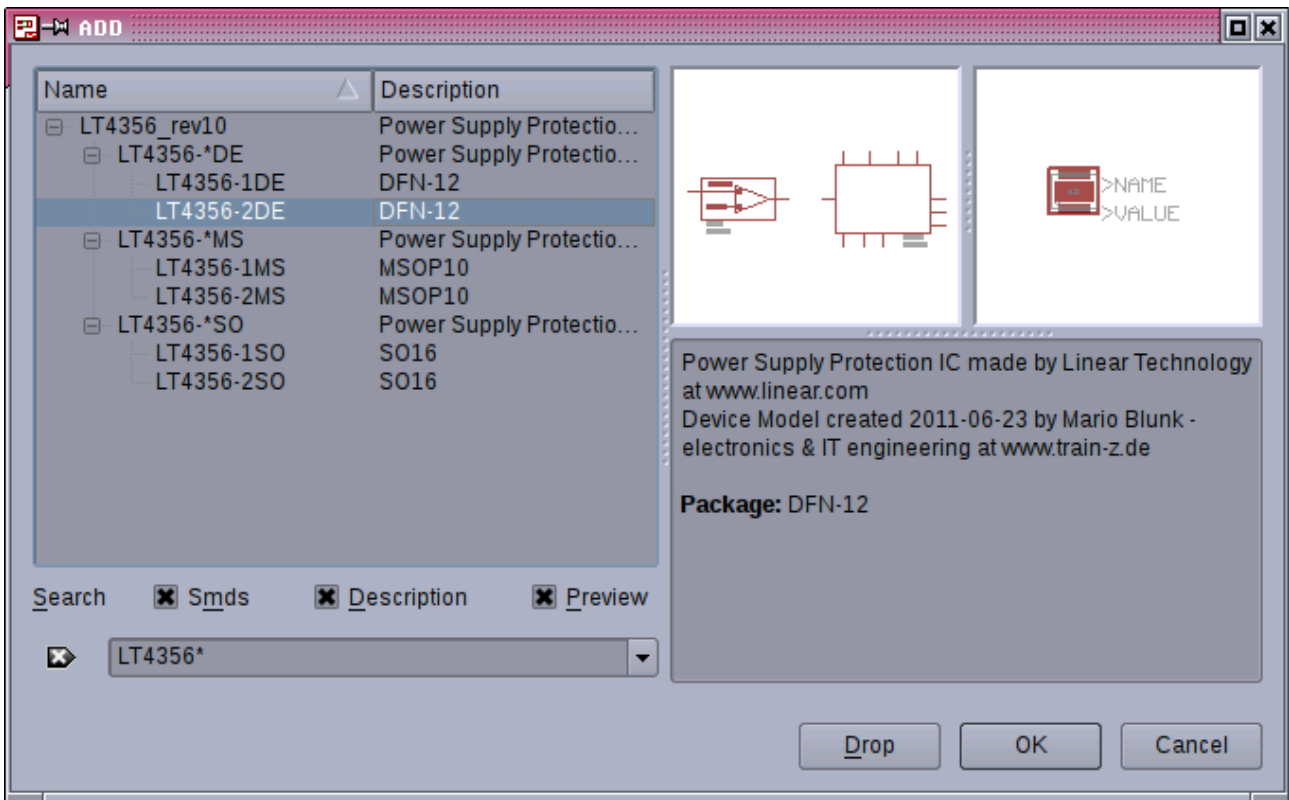

Image 2: Library Structure and Preview from the Schematic Editor

2 Workflow

The general workflow of creating the device model in *EAGLE* is shown below:

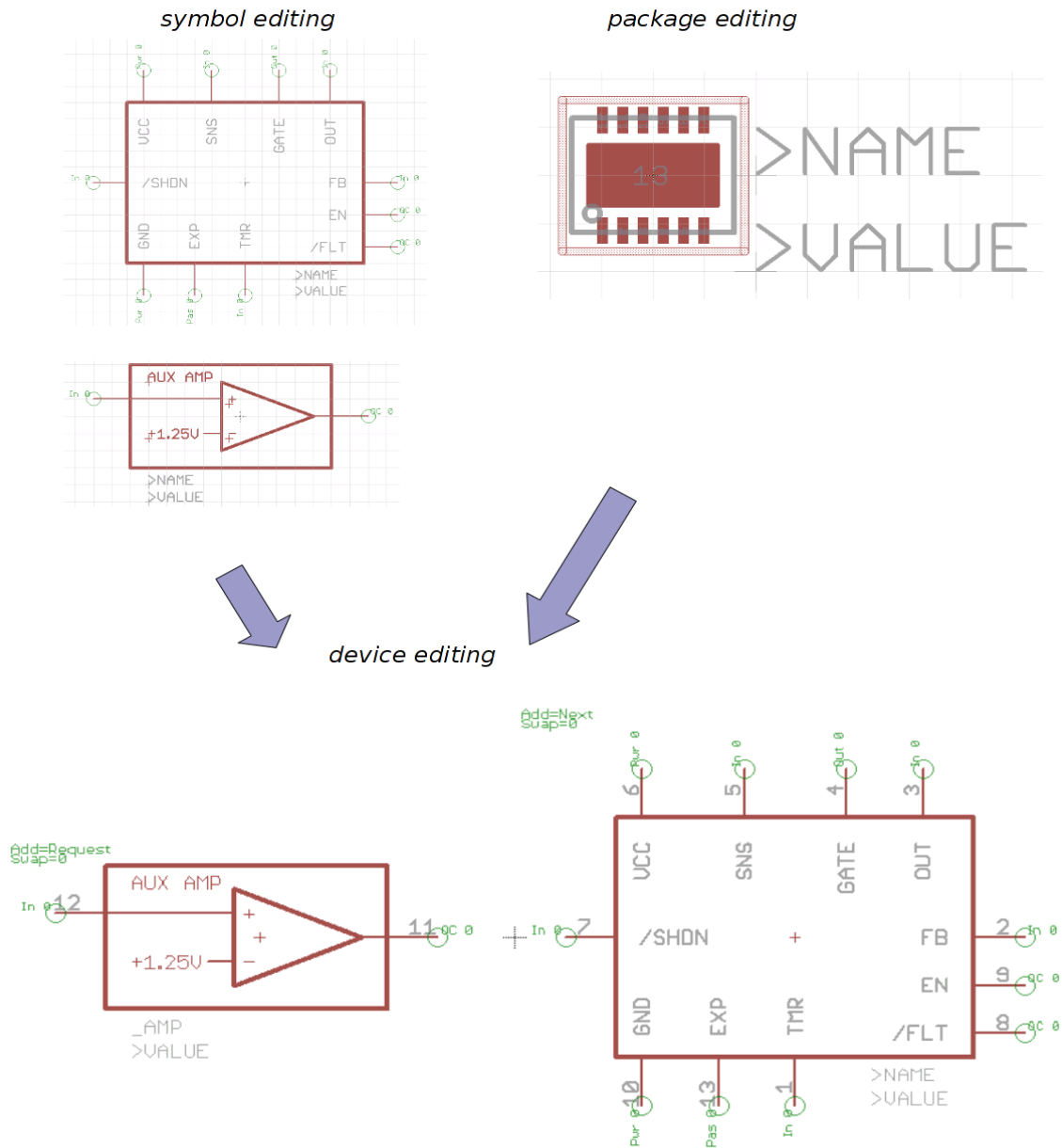

Figure 4: General Workflow

Some rules apply:

1. The connection of symbol(s) and package(s) makes a **device**.
Note Figure 4: after device editing, pin numbers appear next to the symbol pins.
2. The device name usually gets an extension automatically that tells the package variant.
3. Symbols in general don't say anything about technology or packages³.
4. Several **symbols** may belong to a device (in our case main and amplifier symbol).
5. Several **packages** may belong to a device (in our case DFN12, MSOP10, SO16).
6. The library model is ready for use in schematic **and** PCB layout when symbol(s) and at least one package have been joined to a **device**.

2.1 Creating a new empty Library

To create the library where the *LT4356* should reside in, the control panel is the starting point as shown on Image 3.

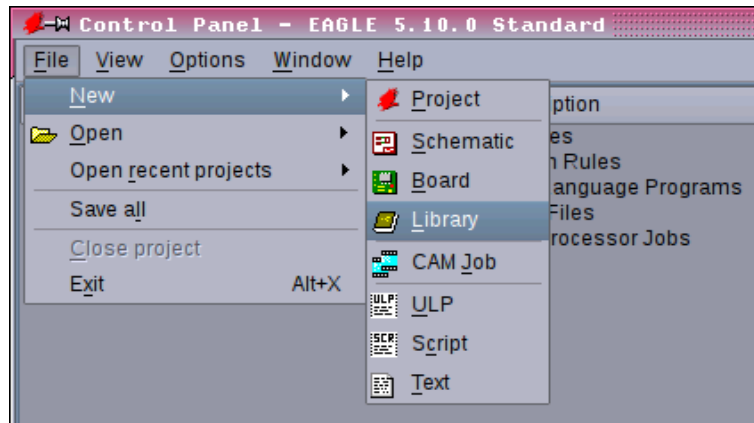

Image 3: Create new Library

Now the new and empty library opens. It should be saved right now somewhere in your home directory⁴ or wherever you have write access to. Since we put only one device in the library, the library name will be **LT4356_rev10.lbr** (Image 4).

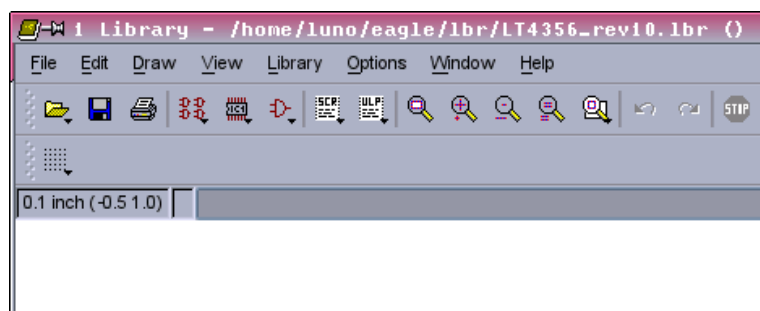

Image 4: The Library saved

Note: The library name can be chosen freely - independent of the library contents. So it could read for example *power_supply_protectors_by_linear_technology.lbr* as well.

³ Putting information about technology or package into the symbol makes the symbol less flexible.

⁴ The path to your home directory/folder is operating system dependent.

2.2 Symbol Editing

Creating the symbol is usually the first step. The symbol defines the appearance of the IC within the schematic.

The usual question at this stage is whether to take existing symbols from another library or to draw new ones from scratch. However, the skills needed to modify an existing symbol are the same as for drawing a new one. Since the *LT4356* symbols are very simple we choose the latter option.

- Click on the symbol icon marked in red on Image 5.

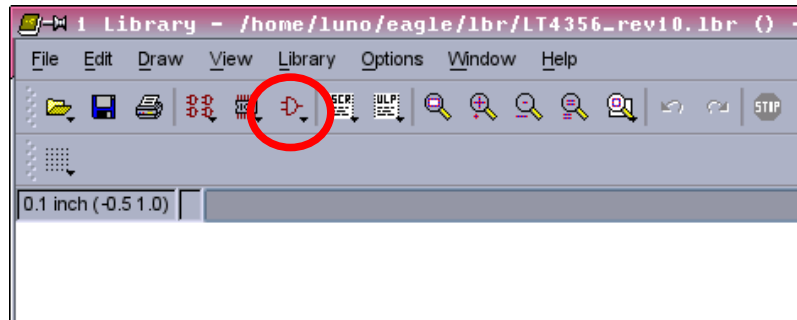

Image 5: Edit a Symbol

2.2.1 The MAIN symbol

Now you are asked for the symbol name. We need several symbols - remember one for the main circuitry and one of the auxiliary amplifier.

- We create the main symbol first and name it *LT4356_MAIN+EXP* as shown on Image 6.

Don't get confused by the buttons Dev, Pac and Sym. They are a leftover from the old times of *EAGLE* :-). Just click on OK.

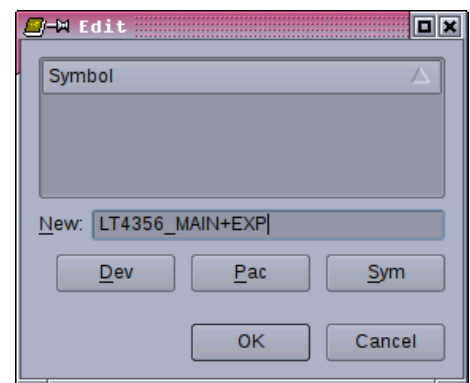

Image 6: Name the Symbol

In case you need to delete or rename the symbol see section 2.6 page 49.

- Say yes to this warning shown right hand.

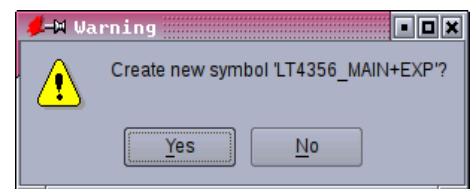

Image 7: Confirm new Symbol

You are taken to the symbol editor itself as shown on Image 8. The drawing area for now is an empty white sheet⁵ showing the current grid only.

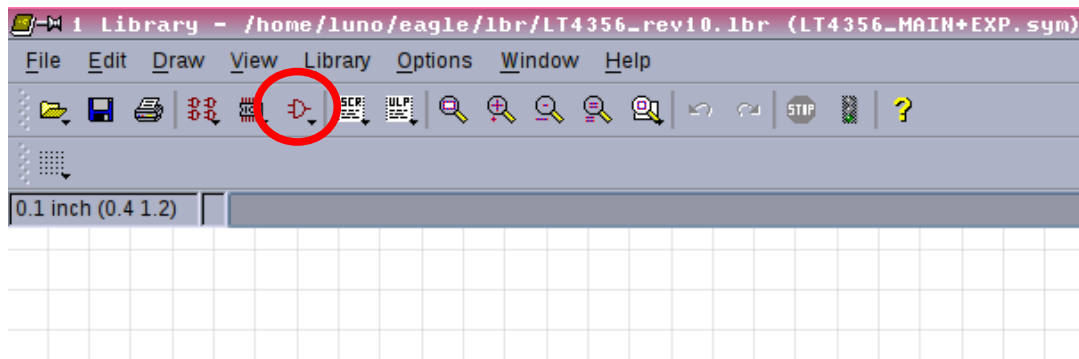

Image 8: Empty Symbol Editor Sheet

- Click again the symbol icon (marked red in Image 8) and create another symbol named *LT4356_MAIN* as shown on Image 9.

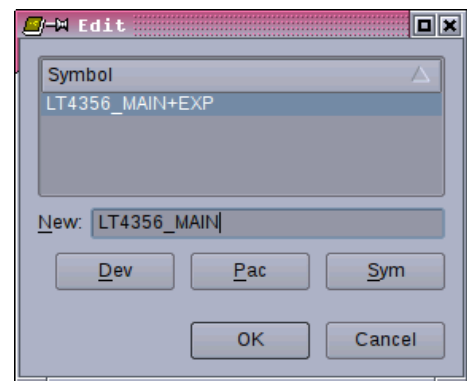

Image 9: New Symbol

2.2.2 The AMP symbol

Now create a third symbol the same way as with the main symbol and name it *LT4356_AMP*.

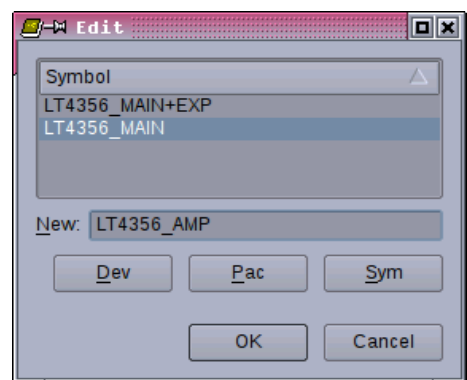

Image 10: New Symbol

⁵ Note the text in the window title bar that reads *LT4356_MAIN+EXP.sym*. This does not stand for a file with extension *sym*. You won't find such a file but inside the library symbols are named this way.

Now that we are here - in the symbol editor for the *LT4356_AMP* symbol - we proceed with drawing this fairly simple symbol:

- ◆ First type the command `wire` or click the wire button⁶.
- ◆ Change line width to 0,016 inch.
- ◆ Draw the amplifier body in layer 94 (symbol layer): a rectangular box with an op-amp inside as shown on Image 11. Don't change the grid that defaults to 0,1 inch.
- ◆ Based on this grid, the amplifier body should be 0,6 inch high and 1,1 inch wide.

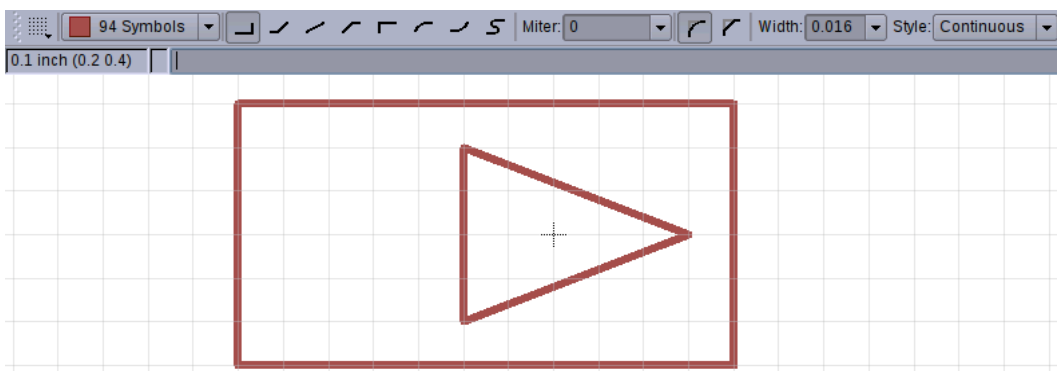

Image 11: Amplifier Body

- ◆ Thinner “wires” going into and out of the op-amp need to be added with the wire command still active. Please change the line width to 0,006 inch (Image 12).

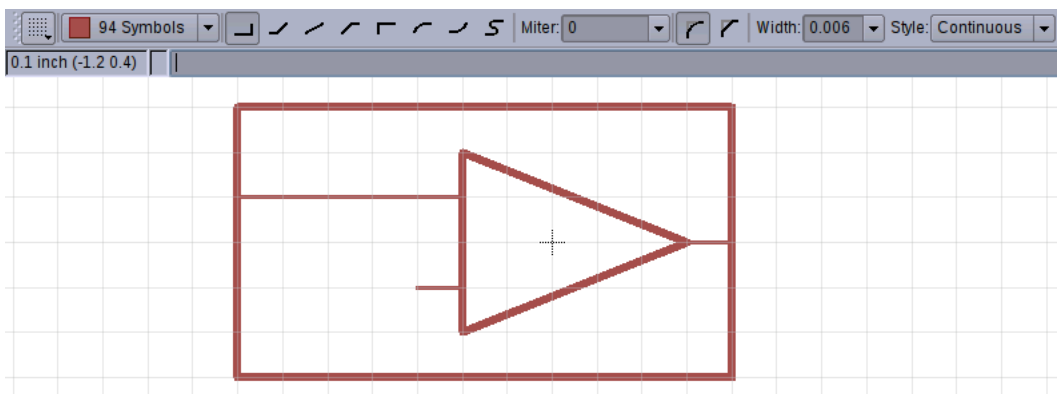

Image 12: Amplifier Body

- ◆ The amp pins should be placed next using the command `pin` (or click the button in the toolbar).
- ◆ Once the pin-mode is active, the pin properties may be set like pin orientation, length, I/O characteristics, visibility. The latter should be set by click on the property button framed in red on Image 13. This way the pin name will not be shown in the schematic later on, whereas the pad number is visible.

⁶ Although the term wire resembles an electrical wire, “wire” here means all kinds of lines in whatever layer.

Why hiding the pin name ? The way a pin is placed, in our example the amplifier input and output, speaks for itself and may overlap with segments of the symbol.

- ◆ When placing the single input pin, set direction to “in” whereas the output pin needs setting “OC” (open collector/drain as shown on Figure 2 on page 4).

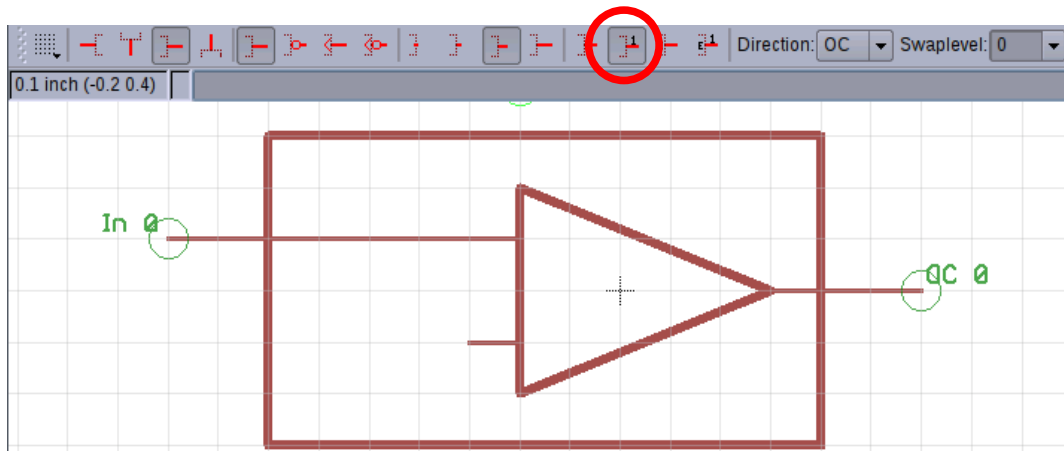

Image 13: Amplifier Input and Output Pins

- ◆ After that, give the pins a name (as shown on Figure 2 on page 4) running the command `name` and click on the pin. The input pin will be given the name `IN+` and the output pin will be named `AOUT` (Image 14).

Note : Due to the visibility property we have set before, you don't see the pin name here. You may change the visibility and see what happens.

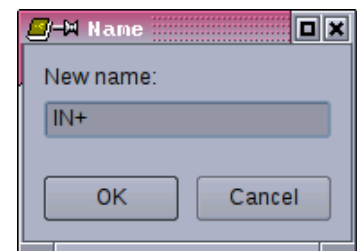

Image 14: Naming Pins

- ◆ Whenever the command `info` is active, clicking on a pin gives you the pin properties.
- ◆ Now some text is needed as shown on Image 15. The input pins need the “+” and “-” sign. The inverting input pin is hardwired inside the IC to a reference voltage of +1,25V. By means of the command `text` this cosmetic work is an easy task. Note, the alternative grid of 0,01 inch is required when placing the text. The alternative grid is active while the keys `Ctrl+Alt` are being pressed.
- ◆ With the `text` command the “>NAME” string needs to be placed in layer 95 (Names) and the “>VALUE” string in layer 96 (Values). The “>” sign defines a placeholder. All letters must be capital. Later in the schematic the name will be something like IC43 whereas the value will be something like LT4356-1.

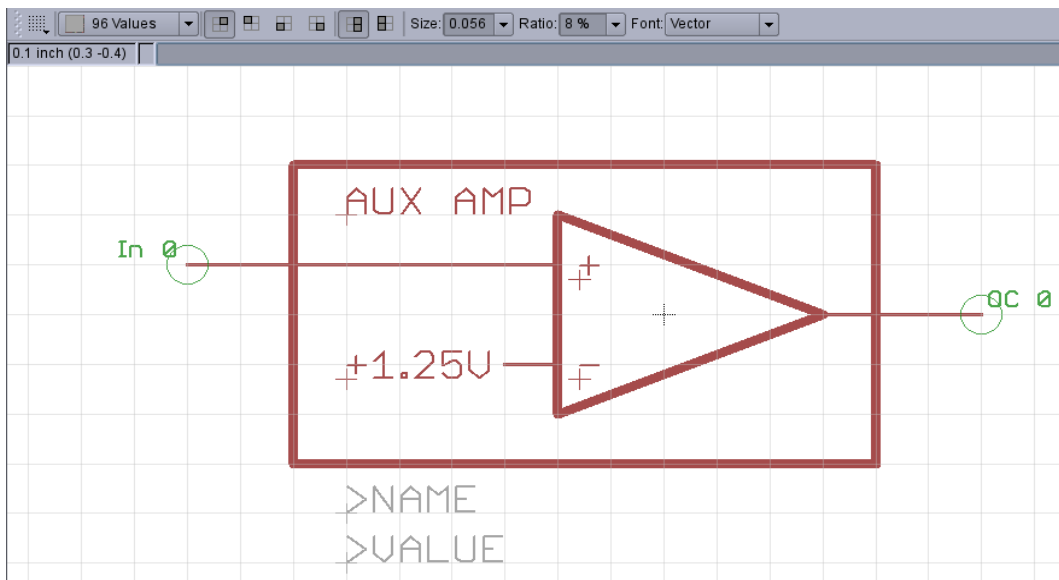

Image 15: Placing Text Labels

- ◆ For all text labels I recommend vector font text size 0,056 inch and a ratio of 8%. 8% ratio means 8% of 0,056 inch → that yields about 4,5 mil or 0,1mm line width).
- ◆ Save the library and we are done with the first symbol.

2.2.3 Drawing the MAIN Symbols

These symbols have some more pins but the body is easier to draw in contrast to the AMP symbols – it is just a rectangular box as depicted on Image 16.

Since the actions needed to get these symbols are basically the same as for the AMP symbol we don't go through them again. One exception is the **pin visibility mode** set to “both” (property button framed red). So, while naming the pins you see their names in order not to get confused.

The difference between the symbol *LT4356_MAIN+EXP* and the *LT4356_MAIN* is that the first has the pin EXP and the second doesn't.

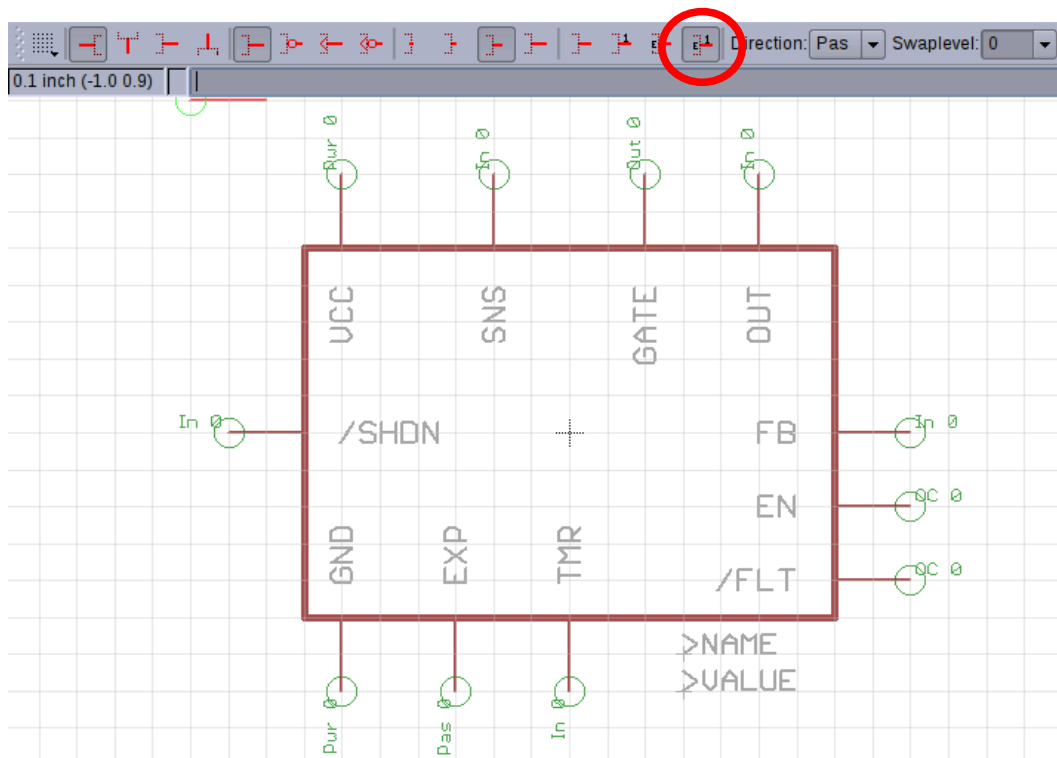

Image 16: Symbol *LT4356_MAIN+EXP*

The symbol *LT4356_MAIN* is easy to get.

- ◆ Just run the command `group all`, whereupon the whole symbol gets highlighted.
- ◆ Type the command `cut`, left click somewhere on the symbol to get it into the clipboard⁷.

⁷ The well known term “copy&paste” means in the *EAGLE* world “cut&paste”.

- Now click the symbol icon as marked red on Image 17.

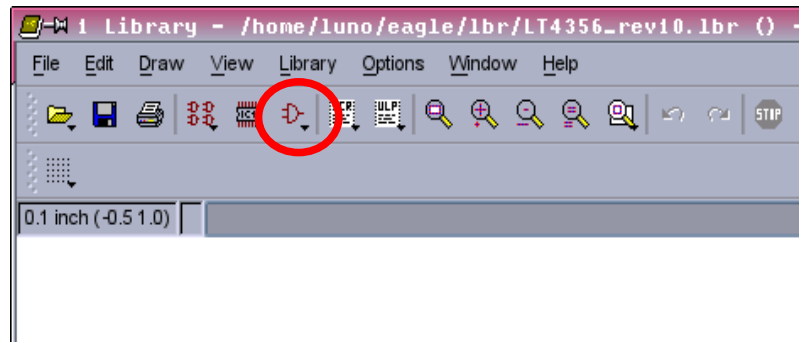

Image 17: Open Symbol

- Select the symbol `LT4356_MAIN` from the box that comes up then (Image 18).
- The symbol editor opens with an empty sheet. Run the command `paste`. The `LT4356_MAIN+EXP` symbol should be attached to your cursor now. Place it so that the origin is right in its center. So far it looks exactly as in Image 16.
- Run the command `delete` and left click the EXP pin. The result should look as on Image 19.

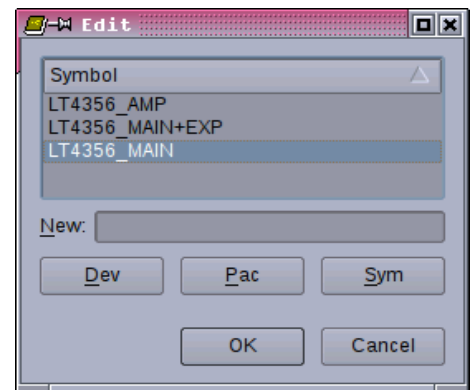

Image 18: Select Symbol

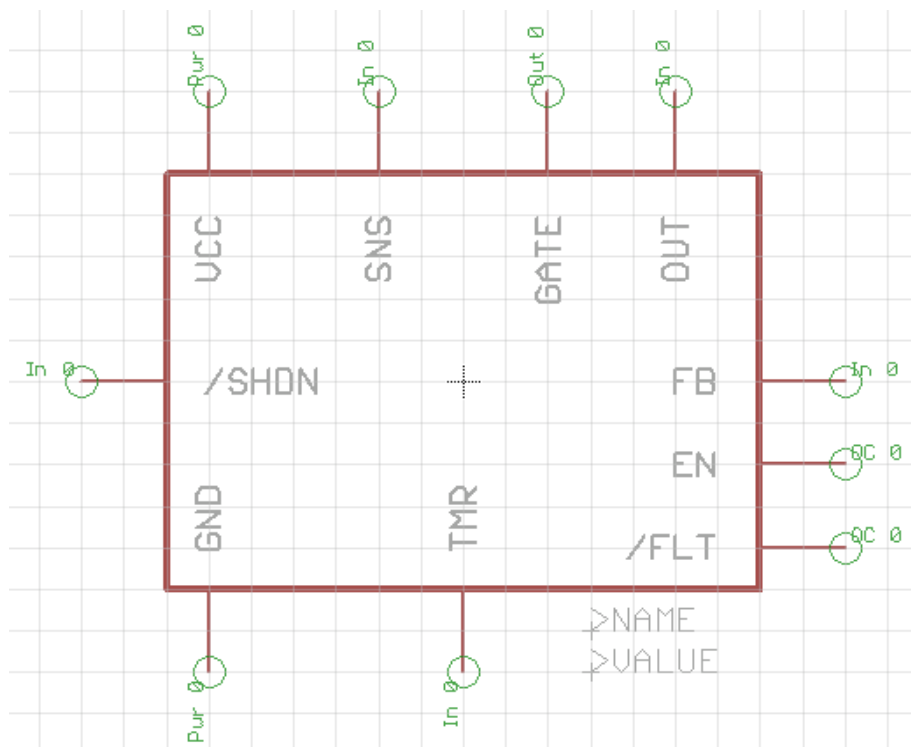

Image 19: Symbol LT4356_MAIN

2.3 Package Editing

The package editor focuses on mechanical properties of the IC like outlines or pad sizes. We start by clicking on the package icon in our library as shown on Image 20.

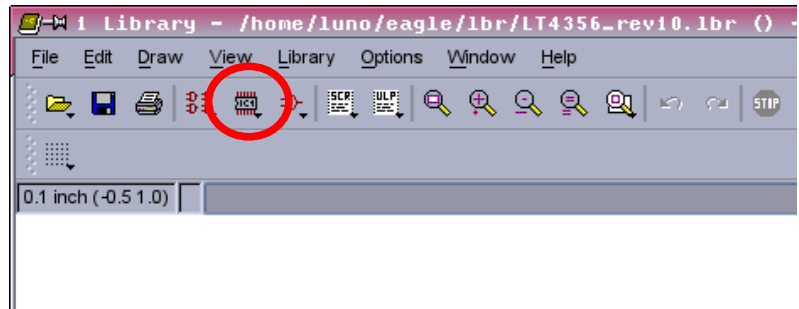

Image 20: Create Package

2.3.1 The DFN package

Now you are asked for the package name. See Image 21.

- ◆ Type "DFN-12" and click OK.

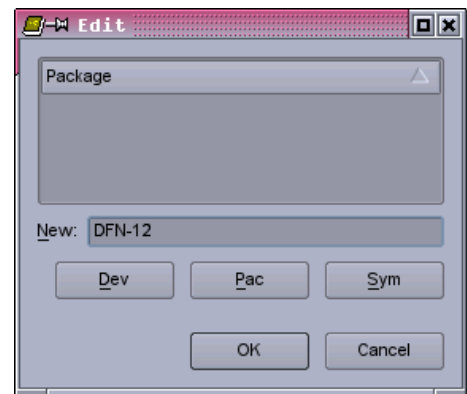

Image 21: Naming Package

- ◆ Answer the following question (on the right) with "yes" whereupon you are taken to the package editor (see Image 23)⁸.

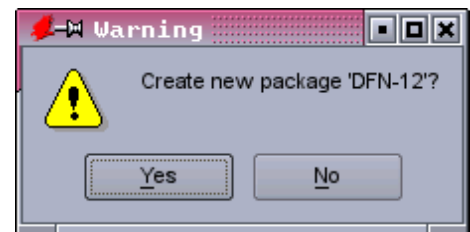

Image 22: Confirm new Package

⁸ Please note the title bar that reads DFN-12.pac. There is no file that ends with pac. Packages inside the library are named this way.

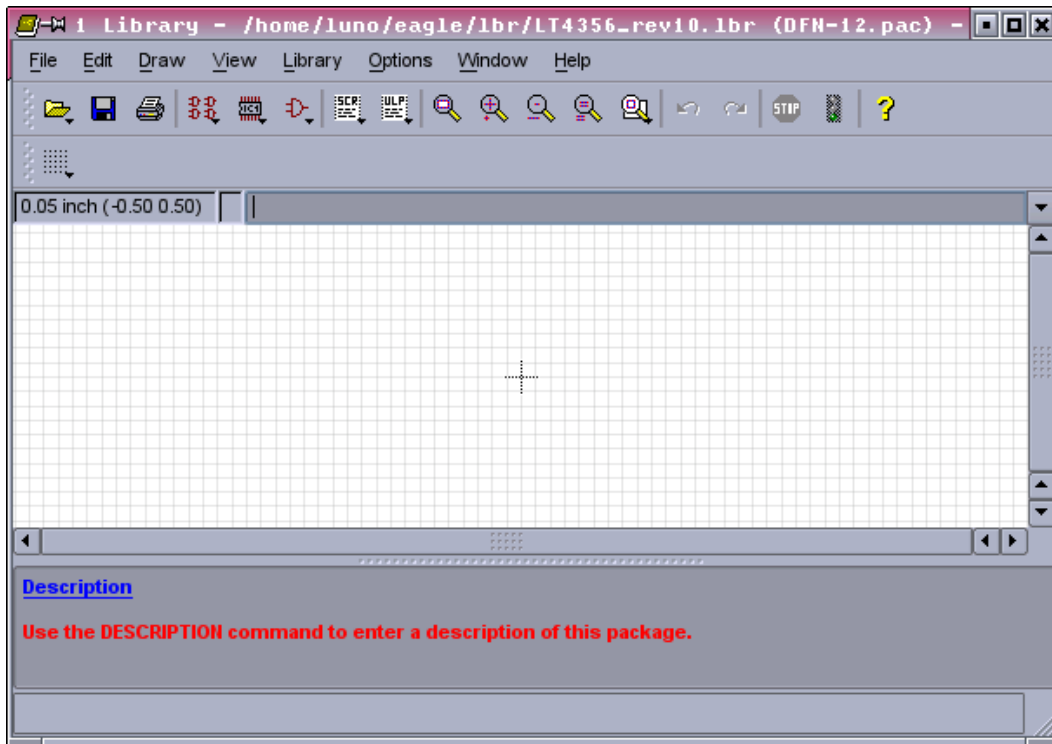

Image 23:

Since most packages are standardized and already drawn in other libraries the packages DFN12, MSOP10 and SO16 we need for the *LT4356* may be copied into our library by drag and drop. Modifying a package requires the same skills as creating one from scratch. So a good training object is to redraw the DFN package shown in Figure 5 on page 20.

A basically important point to mention is note 3 in Figure 5 (marked with a red arrow). Hence the working grid should be set to metric 1,5mm. 1,5mm due to the IC housing outline of 3x4mm which we will draw first.

- ◆ By typing the command `grid` (or clicking on the grid-button) a box opens where you enter the grid we need now. Please also enter the alternative grid of 0,1mm for fine tunings (Image 24).

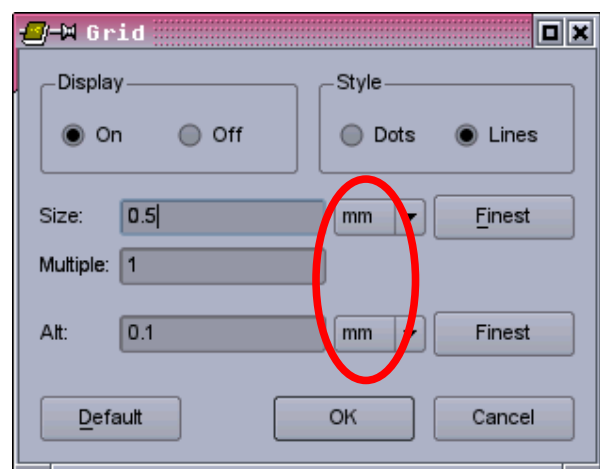

Image 24: Metrical Grid Settings

- ◆ Back in the editor window type the command `wire` and draw the IC housing- a 3x4mm box in layer 21 (tPlace) around the origin (marked with a red arrow). Use line with of 0,127mm (which equals 5 mil in imperial system) as shown below on Image 25.
- ◆ The pin 1 top mark can be drawn using the command `circle`. Once this command is active, click where the circle center is supposed to be, then press `Ctrl+Alt` key simultaneously and click again where the circle outline should be. The outcome of your actions should look as shown on Image 25.

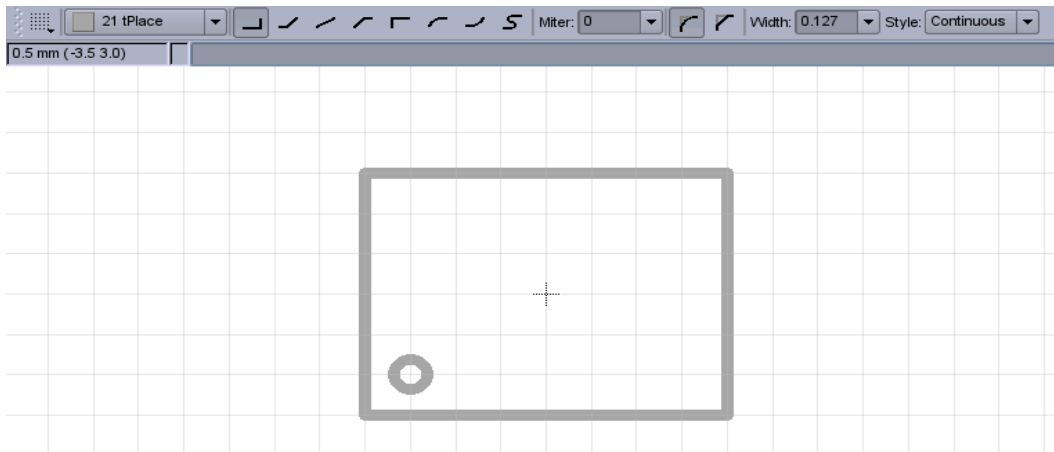

Image 25: Drawing the IC housing

- ◆ Next we add the SMD pads with the command `smd`. The information of pad sizes and where to place them is provided by the red framed part of Figure 5. As soon as the `smd` command is in action a pad is attached already on the cursor. Just place it somewhere next to the housing as shown on Image 26.
- ◆ Change the grid to 0.25mm.

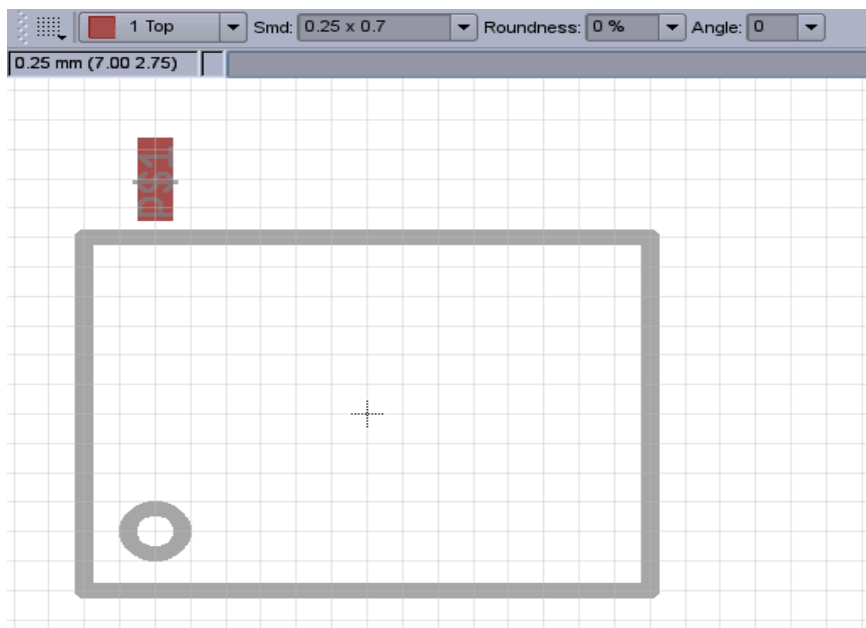

Image 26: Placing a Pad

Now the fine positioning:

- ◆ Enter the command `info` and click on the pad. A box opens where we enter the name and exact position of pad one. The position refers to the geometrical center of the pad.

The X position can be calculated by:

$$X = \frac{-2.5\text{mm}}{2}$$

The Y position is:

$$Y = \frac{-2.2\text{mm}}{2} - \frac{0.7\text{mm}}{2}$$

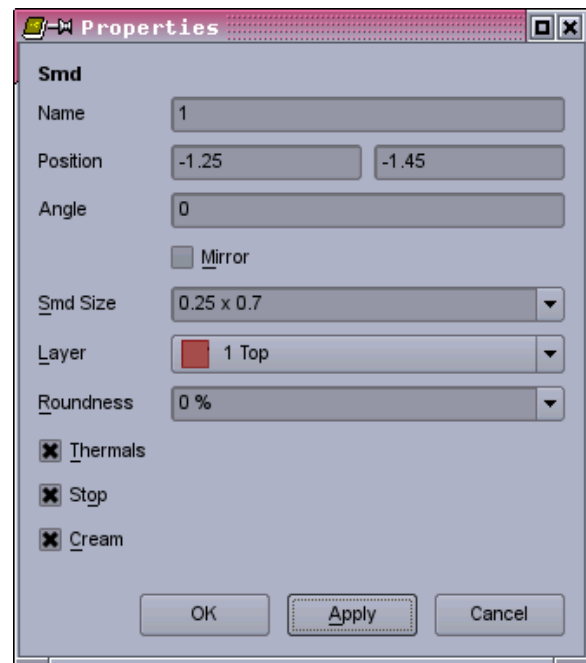

Image 27: Pad Properties

The pad size is 0.25 x 0.7.

- ◆ Leave all other settings in that box as they are and click OK (Roundness 100% means sharp rectangular pads, roundness 0% means round pads⁹. Thermals, solder stop mask and solder cream are added automatically by default.). The pad number one now snaps into the position defined by the footprint drawing of Figure 5.
- ◆ Pads #2 to #6 can be copied using the command `copy`. Once this command is active, click on pad one, then click two vertical grid lines to the right again to place pad number 2. Repeat these steps until the lower row is complete as shown on Image 28. The pad numbering is done automatically¹⁰.
- ◆ If the housing “wires” drawn in layer 21 disturb you reading the pad numbers, make use of the command `display` and uncheck layer 21.

⁹ When placing round pads for BGA packages the roundness must be set to 100%.

¹⁰ To show or hide the pad names check/uncheck in Options/Set/Misc.

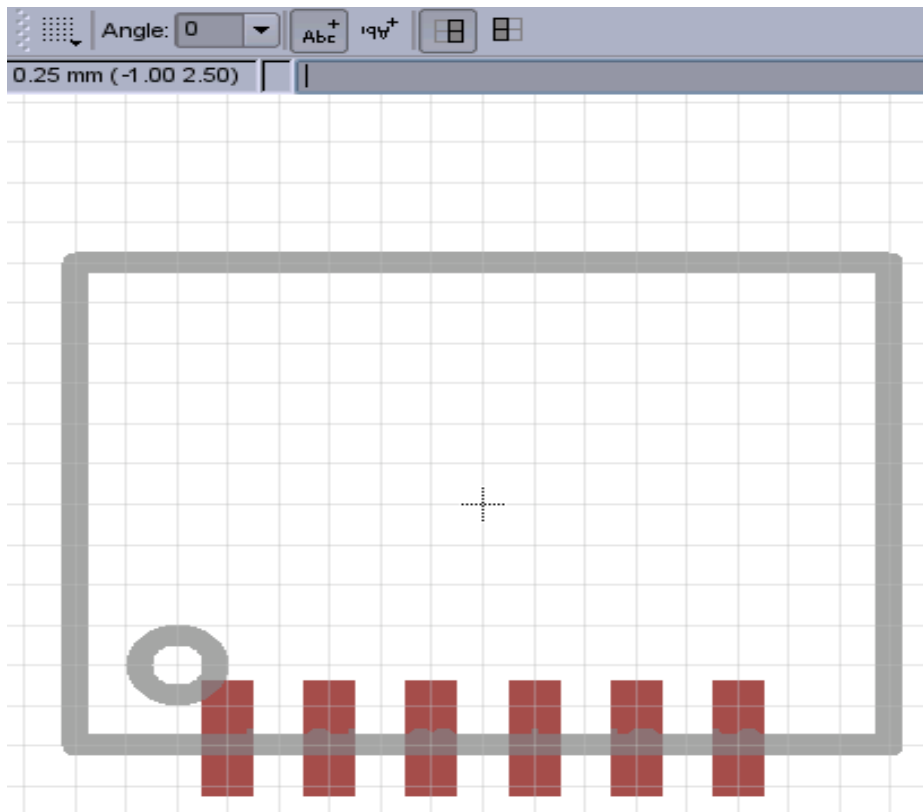

Image 28: Place Pads #2 to #6

- ◆ The upper row starts with pad #7 which we get by copying one of the already placed pads. Just place pad #7 somewhere near the upper right corner of the housing (Image 29).

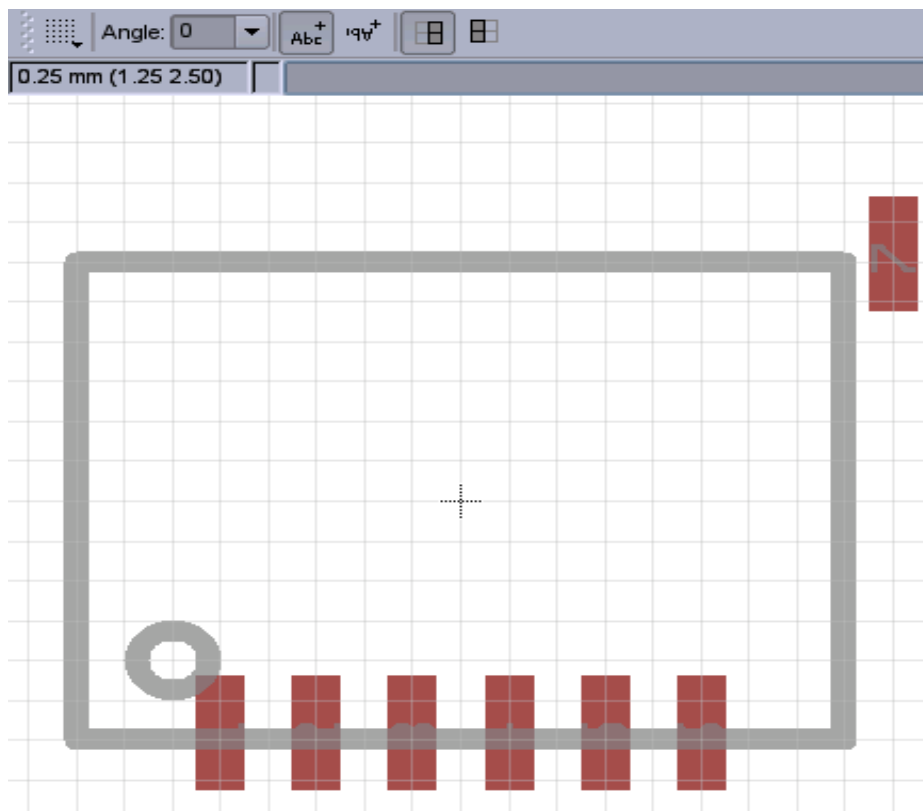

Image 29: Place Pad #7

Again fine positioning:

- ◆ Enter the command `info` and click on pad #7. Enter the exact position of the pad.

The X position can be calculated by:

$$X = \frac{2.5\text{mm}}{2}$$

The Y position is:

$$Y = \frac{2.2\text{mm}}{2} + \frac{0.7\text{mm}}{2}$$

Once applied the pad #7 moves to that position.

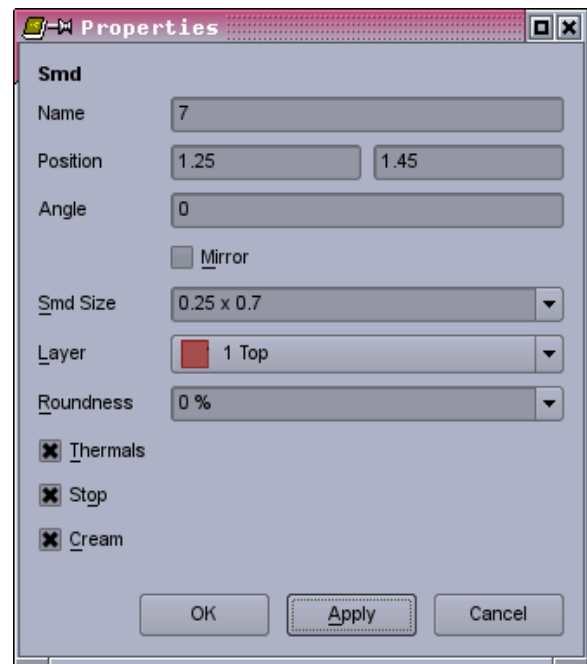

Image 30: Pad Properties

- ◆ By copying pad by pad the upper row can be completed easily. So your work should look as shown on Image 31.

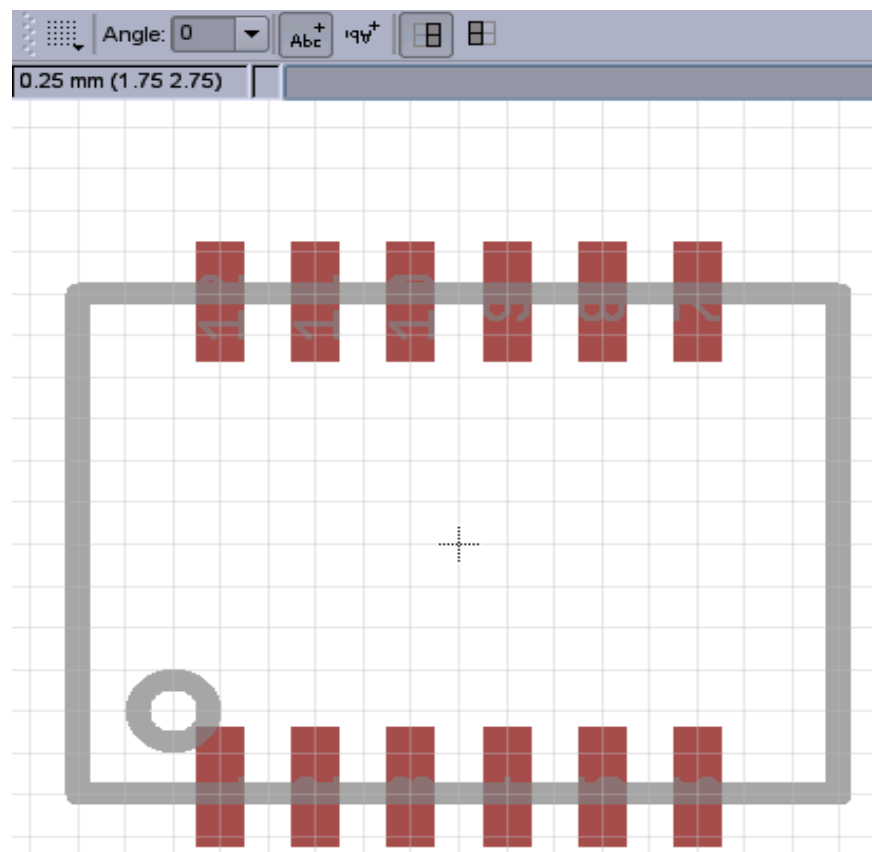

Image 31: Place Pads #7 to #12

One last pad needs to be placed: Pad 13 covers most of the area between the upper and lower pad rows. The datasheet refers to it as the Exposed Pad.

- ◆ Enter command `smd` and place a huge pad as shown in Image 32. Using the command `info` the name 13 is to be given.

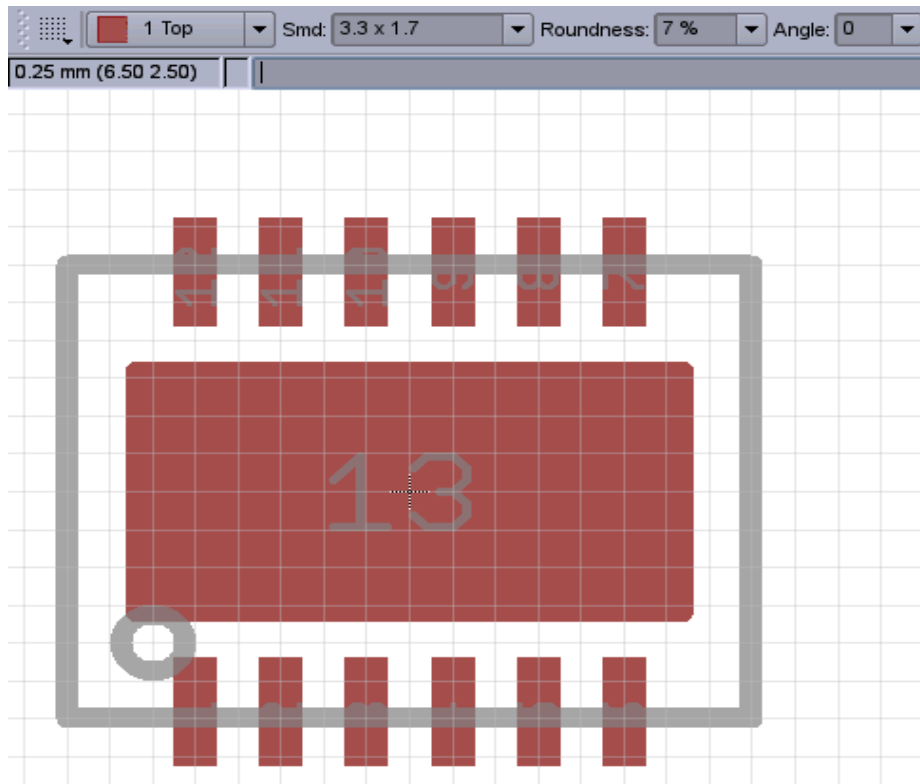

Image 32: Placing the EXP Pad #13

In order to avoid the package placed too close to other SMD components a kind of “safety frame” should be drawn around the package¹¹ in layer 39 (tKeepout)¹².

- ◆ Use the command `wire` and a line with of 0,2mm and draw a rectangular box around as shown on Image 33.

The DRC (Design Rule Check) applied to the PCB layout later on checks for overlaps of these “safety frames”.

11 In general I also recommend this measure for THT packages.

12 Don't care about the bottom layer. The layout editor “mirrors” layer 39 to layer 40 automatically when placing packages on the bottom side of the board.

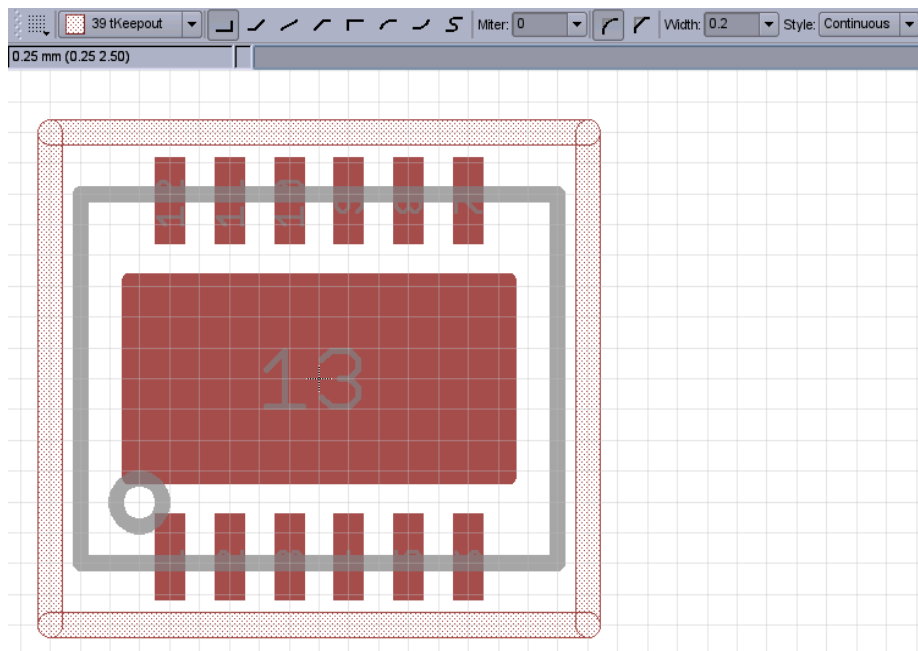

Image 33: Draw Keepout Frame

Now it's a question of favor whether to place the placeholders ">NAME" and ">VALUE" in imperial or metric grid. I prefer the imperial system for them.

- ◆ So using the command `text` we write them in layers 25 (tNames) and 27 (tValues). The advantage of the imperial system are more convenient numbers like the text size of 0,05 inch. Please use vector font and a ratio of 8% (Image 34).

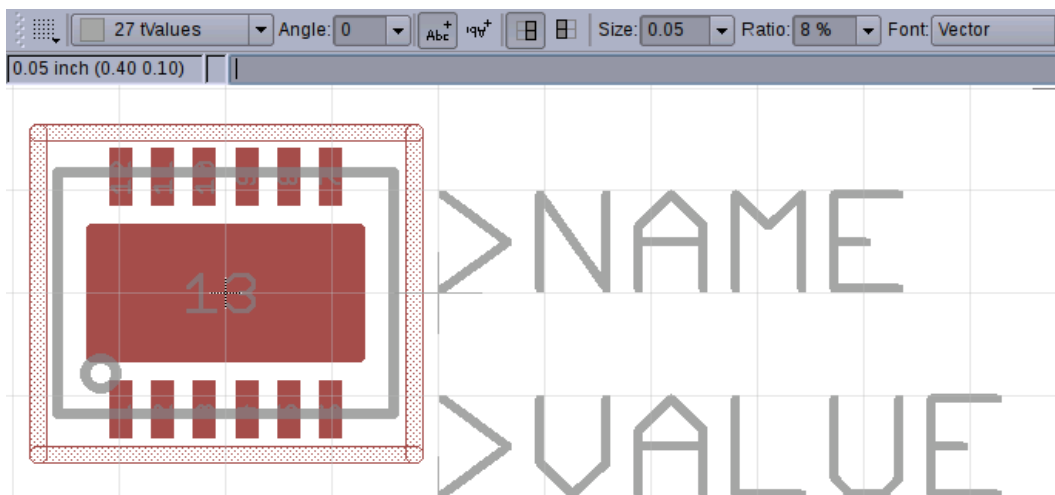

Image 34: Placing Text Labels

During the package editing process a question may have aroused as why texts, pads and wires get drawn in top layers only (tPlace, tNames, tValues, tKeepout). By default all packages are placed on the top side of the board. Using the command `mirror` in the PCB layout editor, the package can be flipped on the bottom side. All segments of the package drawn in layers tPlace, tNames, tValues and tKeepout get mirrored in layers bPlace, bNames, bValues, bKeepout automatically.

2.3.2 The SO package

The *LT4356* is also available in the SO-16 package (see Figure 6). It is widely used by semiconductor manufacturers. So there is no need to draw one from scratch. However, to improve the user skills, drawing one anew is a good training object.

S Package 16-Lead Plastic Small Outline (Narrow .150 Inch) (Reference LTC DWG # 05-08-1610)

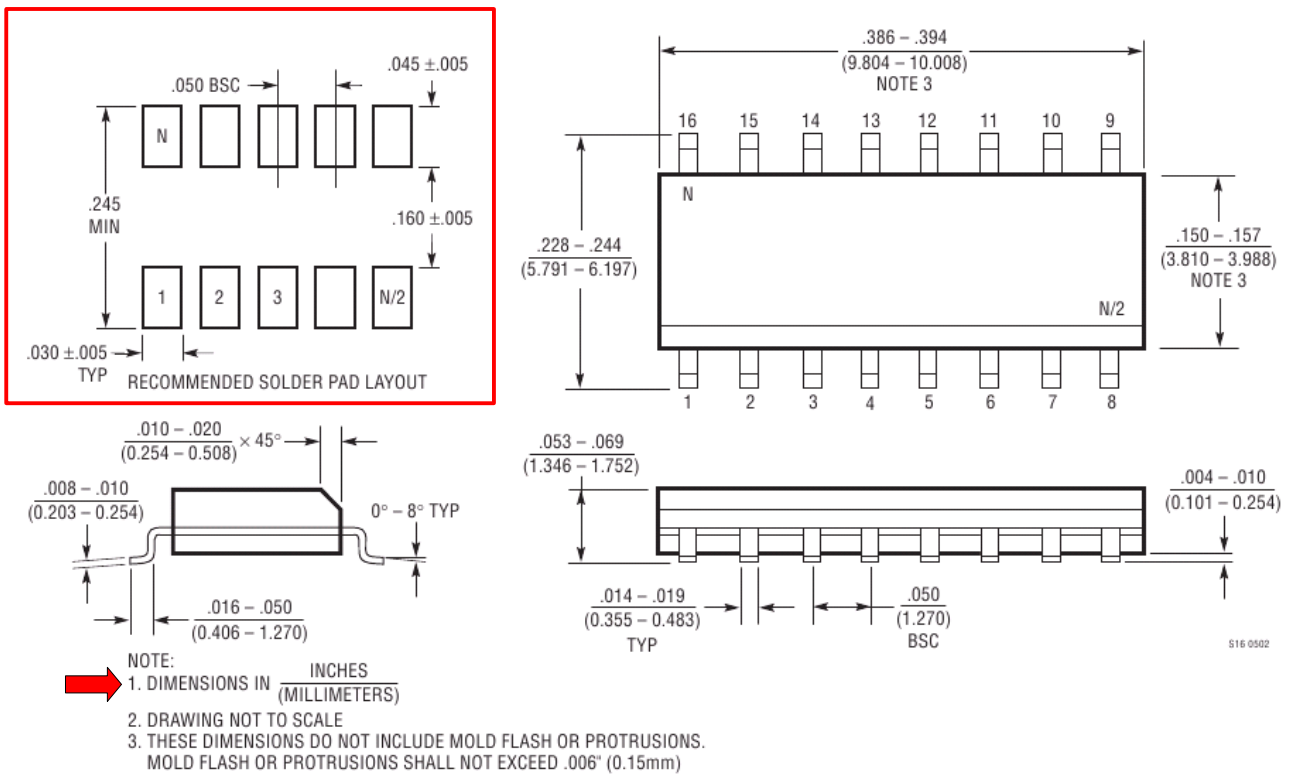

Figure 6: S - Drawing

We drag the EAGLE shipped with package SO16 located in the library *ref-packages.lbr* into our library *LT4356_rev10.lbr* as shown on Image 35.

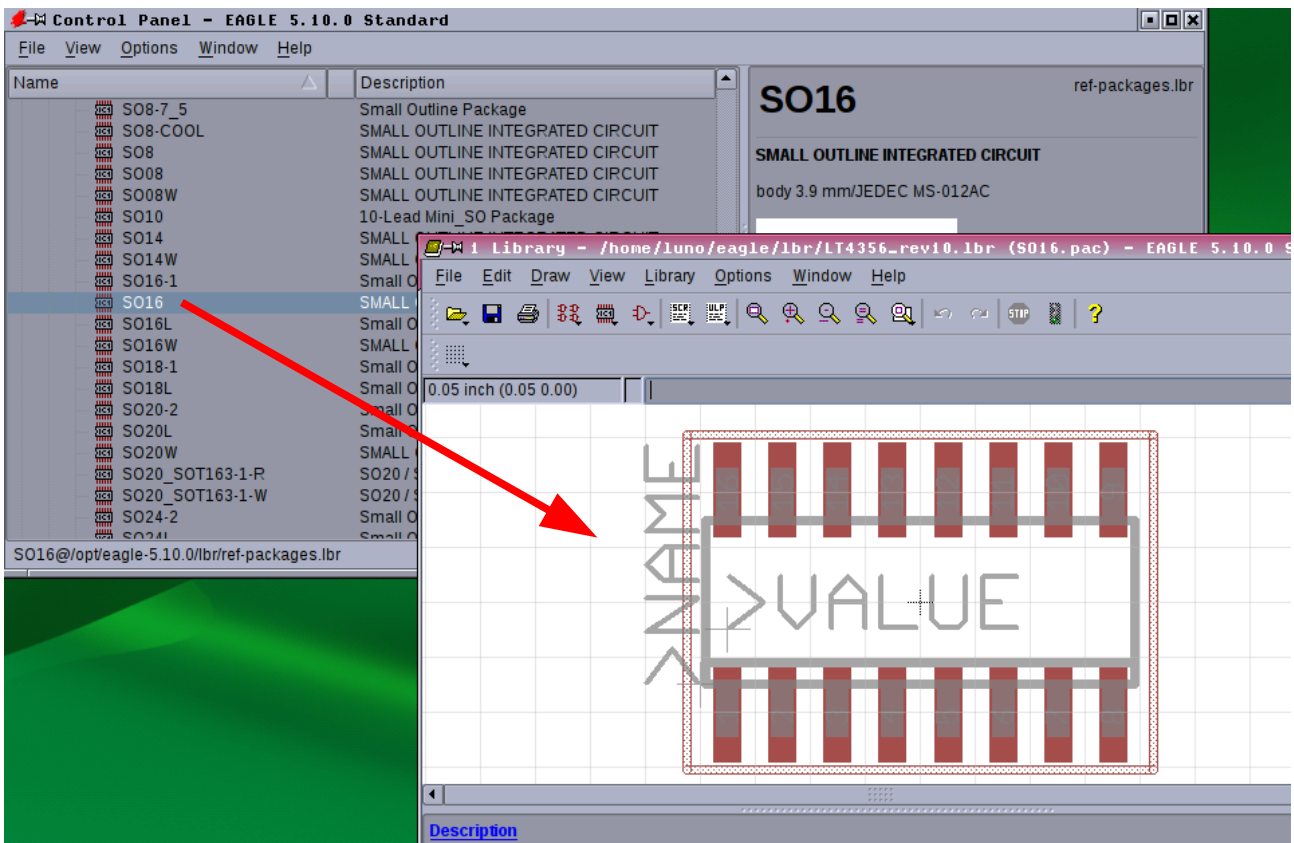
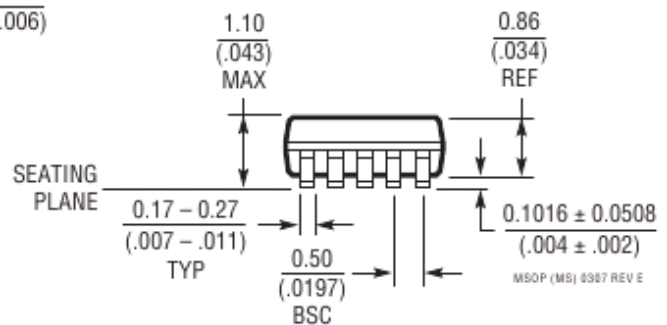
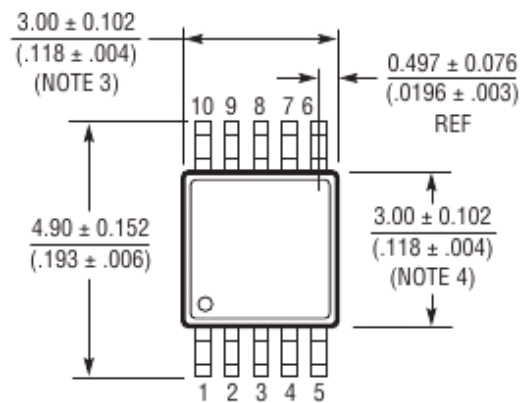
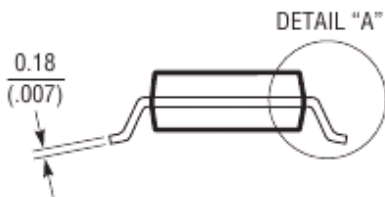
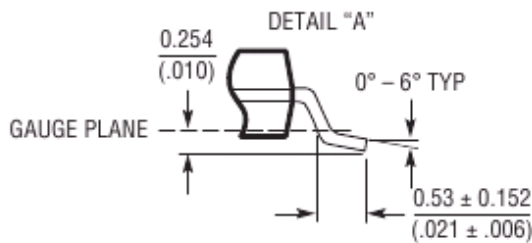
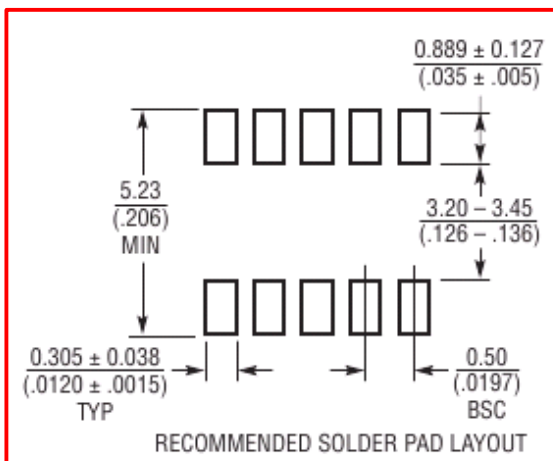

Image 35: Drag & Drop SO16 Package

2.3.3 The MSOP package

Proceed with the MSOP10 package the same way as we did with the SO16 package via drag & drop from the EAGLE shipped package MSOP10 located in the library *ref-packages.lbr*.

MS Package 10-Lead Plastic MSOP (Reference LTC DWG # 05-08-1661)



NOTE:



1. DIMENSIONS IN MILLIMETER/(INCH)
2. DRAWING NOT TO SCALE
3. DIMENSION DOES NOT INCLUDE MOLD FLASH, PROTRUSIONS OR GATE BURRS.
MOLD FLASH, PROTRUSIONS OR GATE BURRS SHALL NOT EXCEED 0.152mm (.006") PER SIDE
4. DIMENSION DOES NOT INCLUDE INTERLEAD FLASH OR PROTRUSIONS.
INTERLEAD FLASH OR PROTRUSIONS SHALL NOT EXCEED 0.152mm (.006") PER SIDE
5. LEAD COPLANARITY (BOTTOM OF LEADS AFTER FORMING) SHALL BE 0.102mm (.004") MAX

Figure 7: MS - Drawing

2.4 Device Editing

The device editor joins symbols and packages to a device.

Note: The EAGLE library allows flexible devices as IC are made with various packages. This feature is useful as long as the pin count and internal circuitry (symbols) **do not** change from package to package. In our case the pin count differs in the DE, MSOP and S version. In addition, the auxiliary amplifier is available in the DE and S version only. So for each package version we need to create a special device.

- ◆ So we need to create a new device. See Image 36.

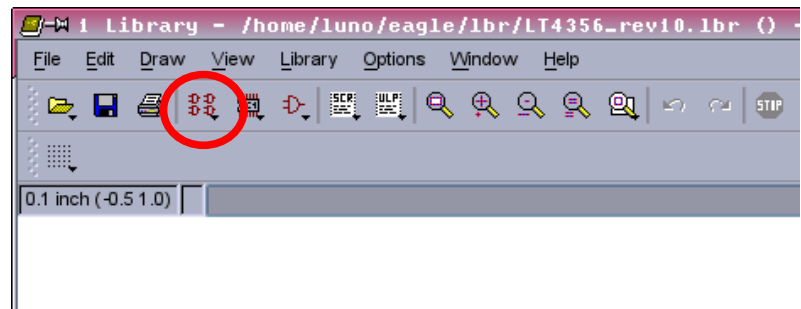

Image 36: Create new Device

2.4.1 The DE-Version

- ◆ Give the new device the name "LT4356-*DE". Note the asterisk which is a placeholder for the technology (That is the electrical version #1 and #2). Read more in sections 1.4 and 1.5 pages 6 and 7 of this tutorial.

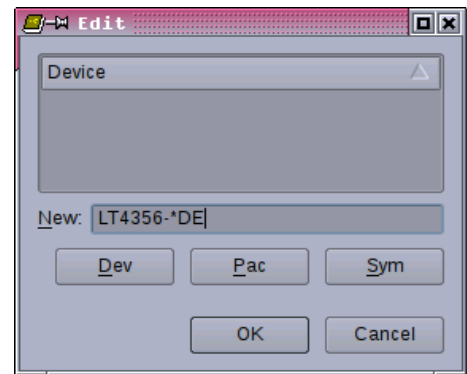

Image 37: Naming Device

- ◆ Say yes to the warning shown on the right.

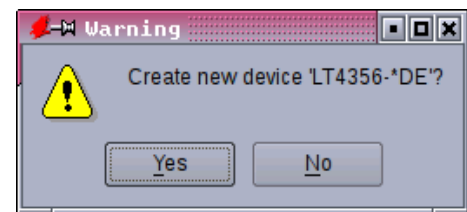

Image 38: Confirm new Device

Now you are taken to the device editor as shown on Image 39¹³.

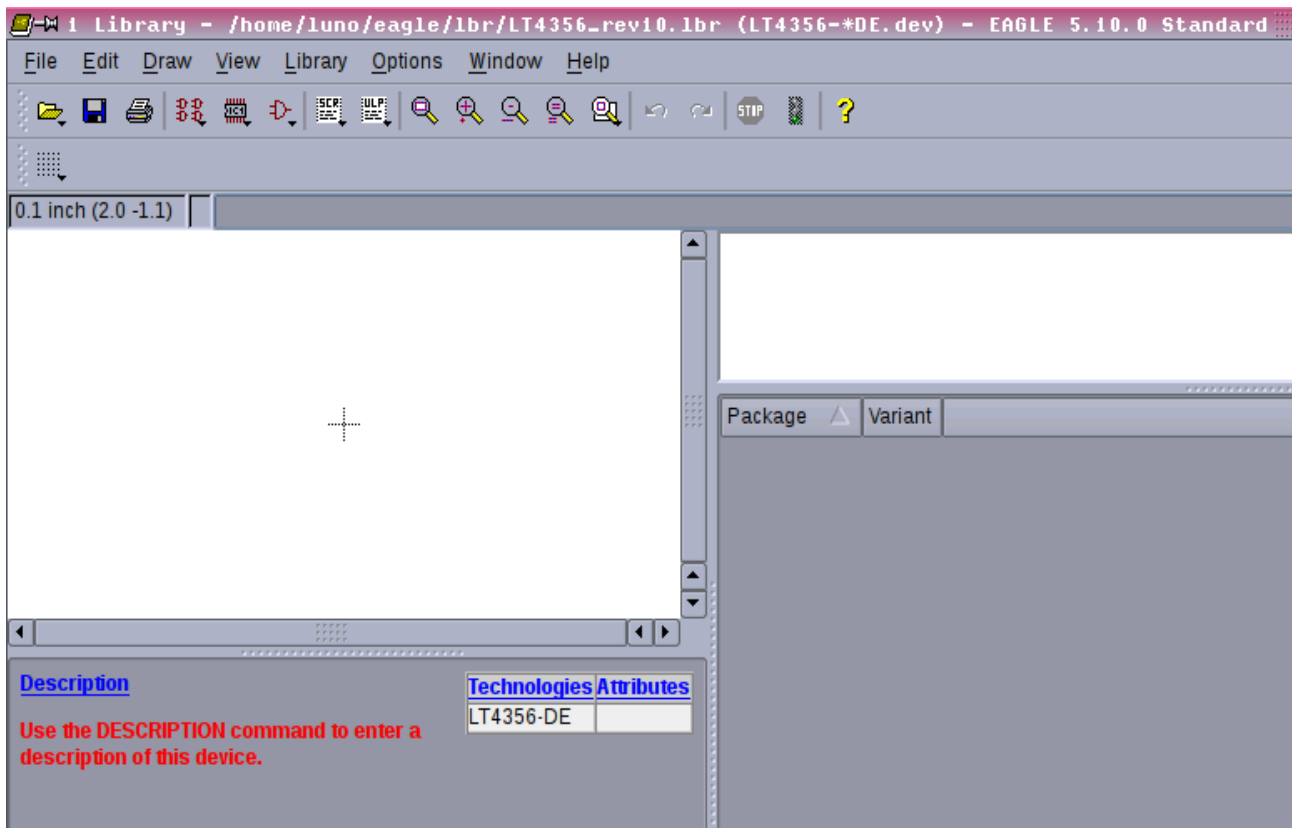

Image 39: Device Editor

2.4.1.1 Symbols

First we'll fetch the symbols needed for the device.

- ◆ Type the command `add` and a box opens where you are asked which symbol of the currently opened library to fetch (Image 40).
- ◆ So select the `LT4356_AMP` symbol and click OK.

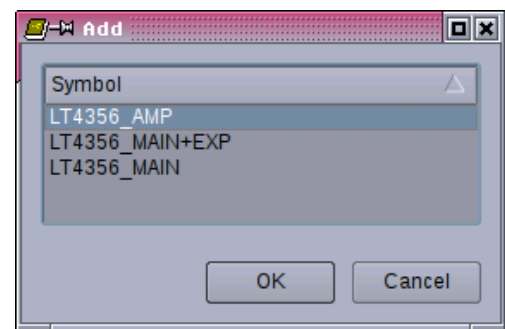

Image 40: Fetch Symbol

¹³ Note the title bar that reads `LT4356-*DE.dev`. You won't find a file like this. Devices are named inside a library this way.

- ◆ Place the symbol attached to the cursor as shown on Image 41.

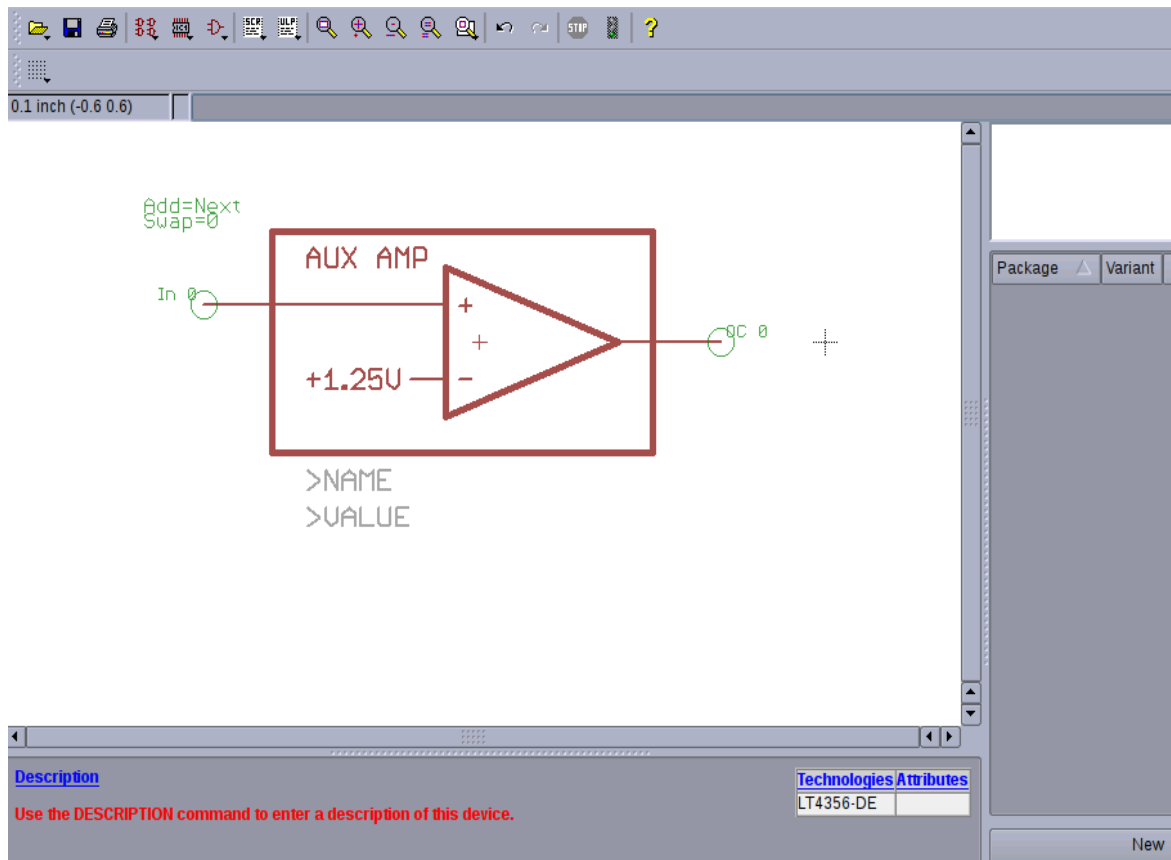

Image 41: Place Amplifier Symbol

- ◆ Once the amplifier symbol is placed, press the ESC key whereupon the symbol selection box comes up again to add further symbols (Image 42).
- ◆ Now select the *LT4356_MAIN+EXP* symbol and click OK. Place this symbol as shown on Image 43.

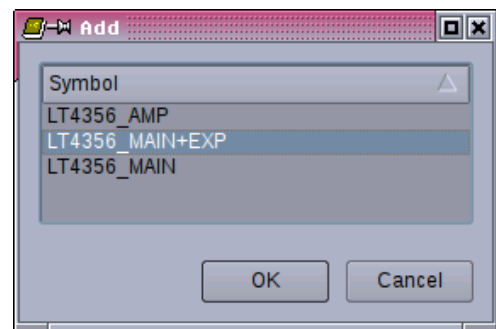

Image 42: Add Symbol

Inside the symbols window you may use the zoom tools and the command `move` to place the symbols around the cross-hair in the center of the window.

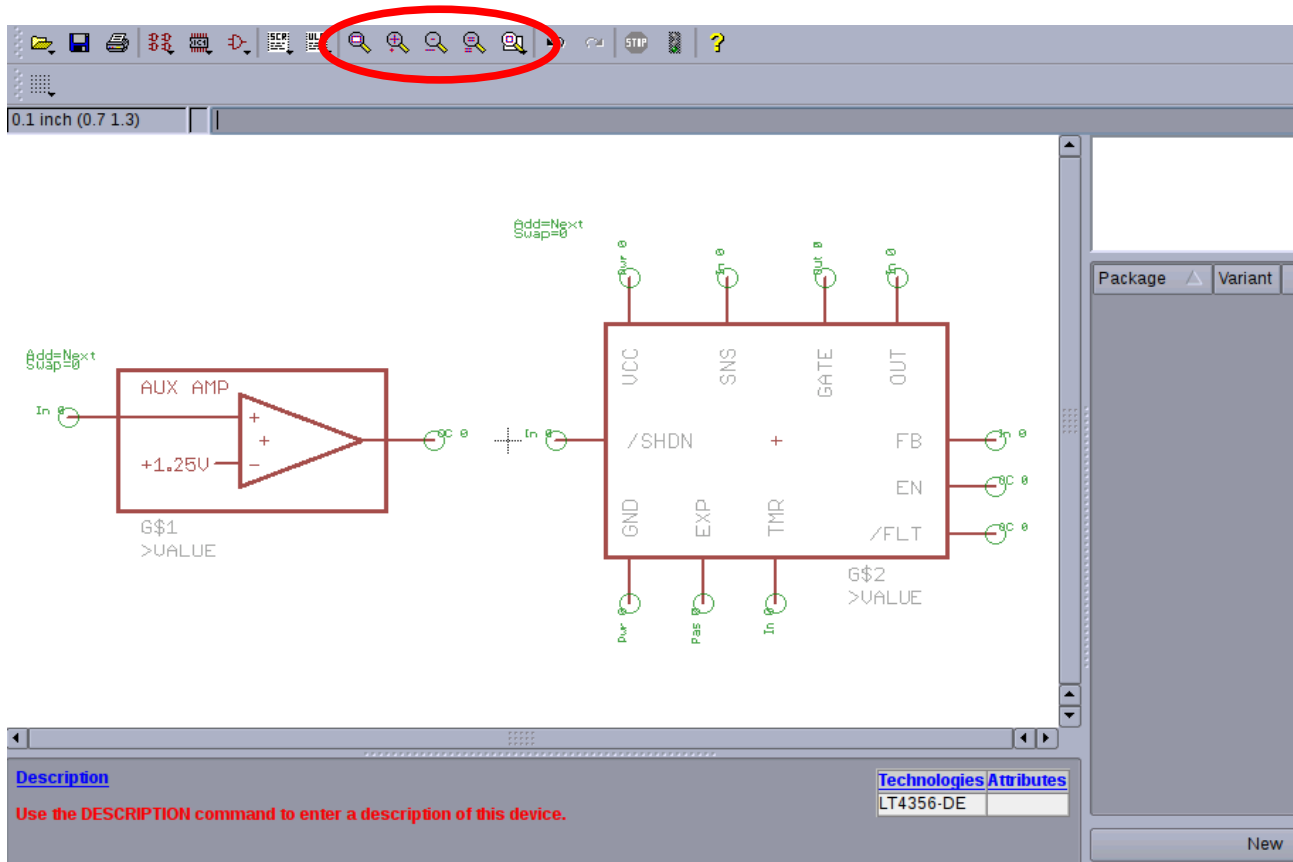

Image 43: Place MAIN Symbol

- ◆ With the command `info` active, click on the origin of the amp symbol. The properties box opens where you do the settings as shown on Image 44.
- ◆ The name should be “_AMP”. Later in the schematic the amplifier name will read `IC7_AMP` for example. Don't care about the X/Y-position and the swap level. Important is the add level “**Request**”. This mode means that the amplifier symbol it to be used in the schematic on the **users request** only.

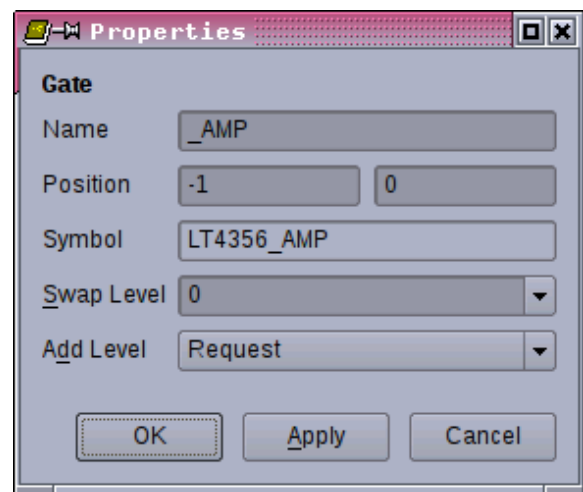

Image 44: Amplifier Symbol Properties

- Now that the `info` command is still active, click on the main symbol and enter the properties as shown in Image 45. Don't care about the positioning but care for the add level "**Next**".

Note: If you discover a mistake in one of the symbols you can go back to the symbol editor any time and iron it out. Symbols already added to the device editor get updated automatically.

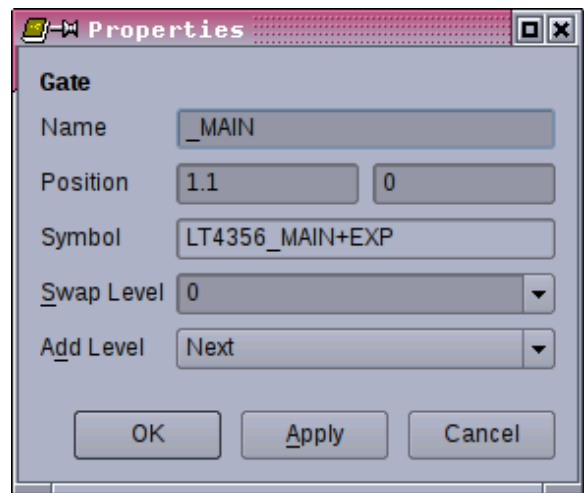

Image 45: Main Symbol Properties

Finally the symbols in the device editor should look as on Image 46.

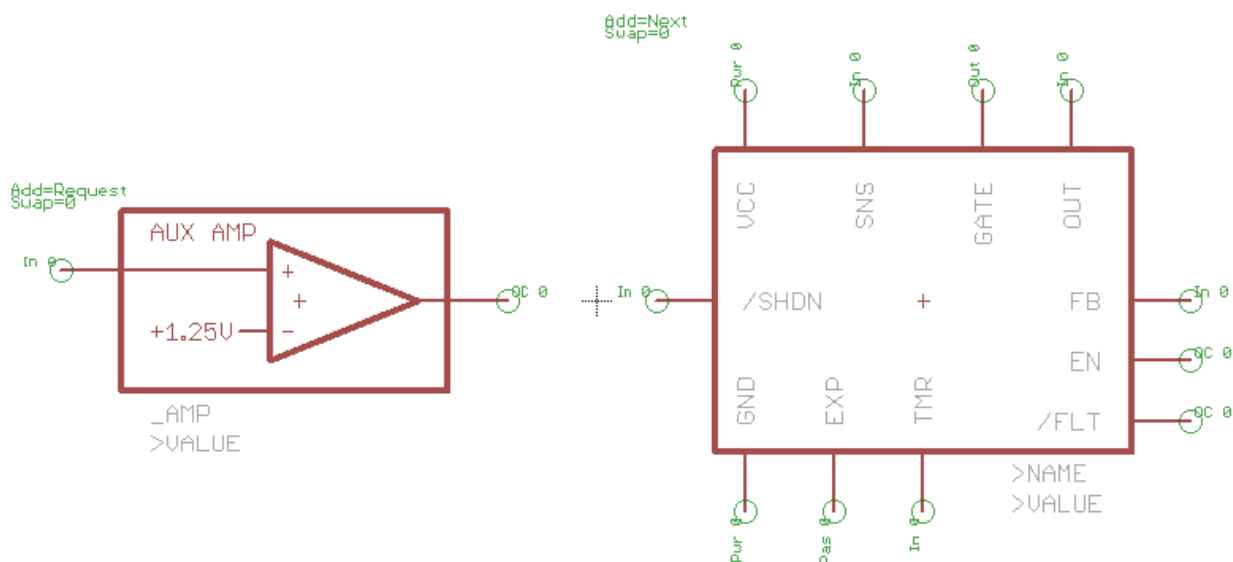

Image 46: Symbols added

2.4.1.2 Package

The symbol assembly we have ready now fits into the DFN-12 package only.

- ◆ Type the command `pac`, a box opens where you select the package to add. In this example, select package “DFN-12” and click OK.

Note: Don't enter a name for this device variant. We've already “hard coded” the package variant name in the device name (see title bar on Image 47). The reason for hard coding the package variant in the device name is that the

symbol assembly we have done above is available in the DE version only. In detail: The symbol `LT4356_MAIN+EXP` has the exposed pin which exists in the DE version only.

By the way the MSOP10 package is visible in the list but can't be added since its pin count (10) is less than the total pin count (13) of our symbol assembly (see Image 46).

Further on, despite the SO16 package can be fetched because of its pin count, it does not have the EXP pin. When it comes to connecting symbols and package later on (section 2.4.1.3 page 36), the EXP pin could be ignored. For a quick and dirty approach this could be acceptable.

- ◆ Click OK and the DFN-12 package appears on the right of the device editor (Image 48). By not giving a variant name on Image 47 the quotation mark (“) now stands for the “non-existing-variant”. If a variant name was given, it would be there instead of the quotation.

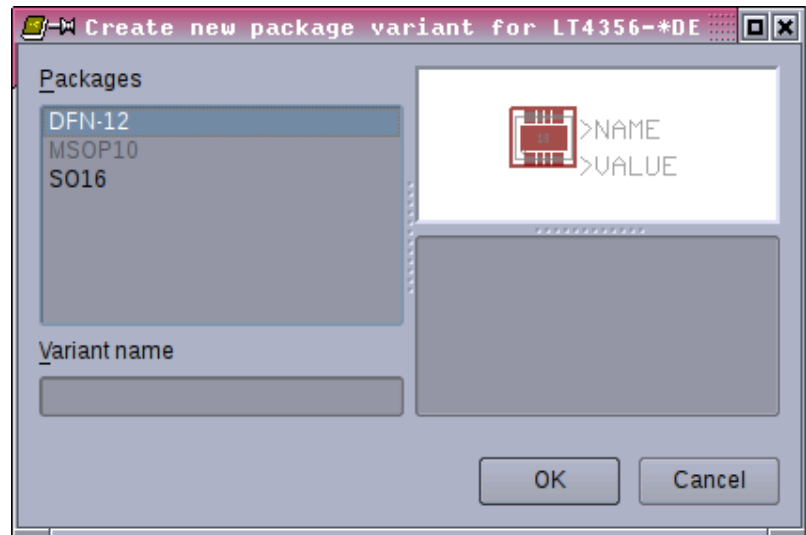

Image 47: Select Package DFN-12

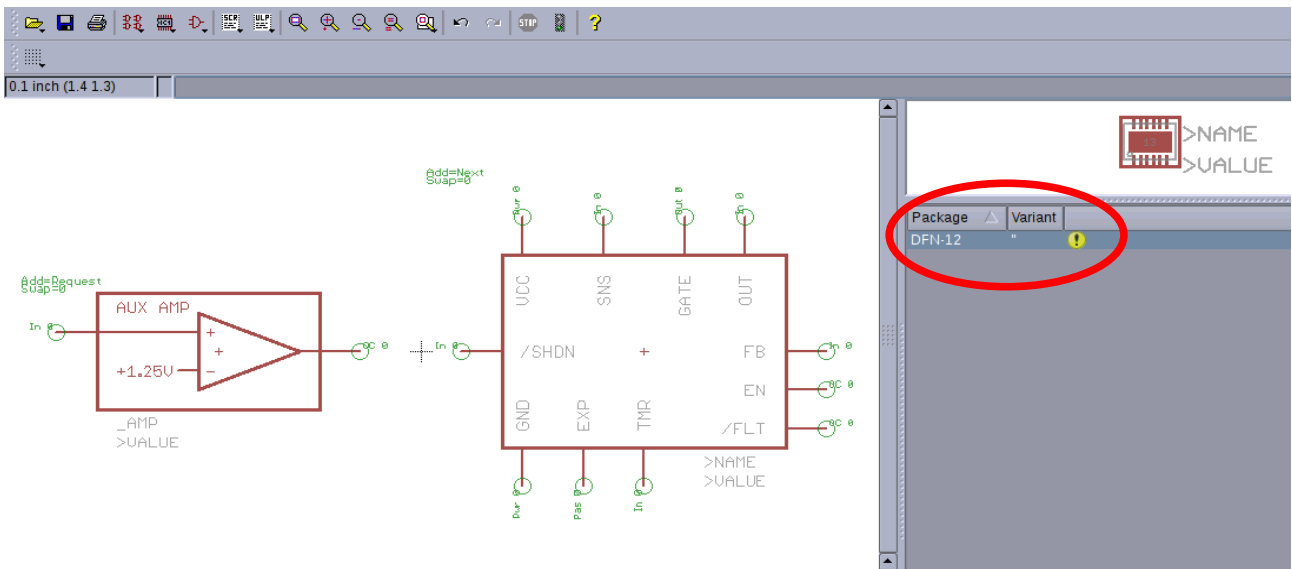

Image 48: Package selected

2.4.1.3 Connecting Symbols with Package

Now an important step of your work is to come.

- Click the “connect” button (Image 49).

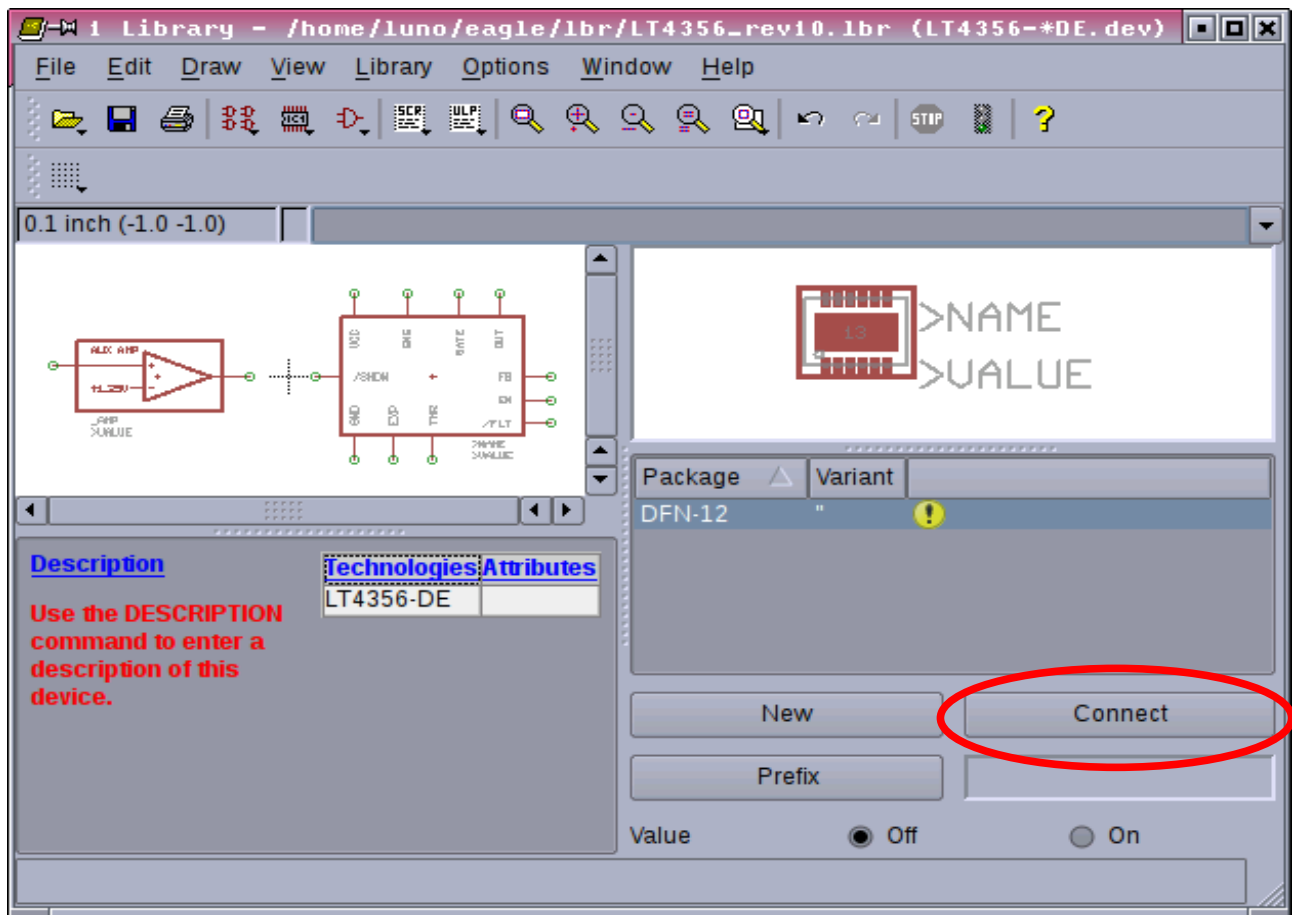

Image 49: Connecting Symbols and Package

A menu opens where you are to connect symbol pins and SMD pads one by one (Image 50).

Note: When doing this error prone job for very large devices like a 1500 ball BGA you can click OK, save the library, shut down the computer, have a break and proceed whenever your concentration is back :-)

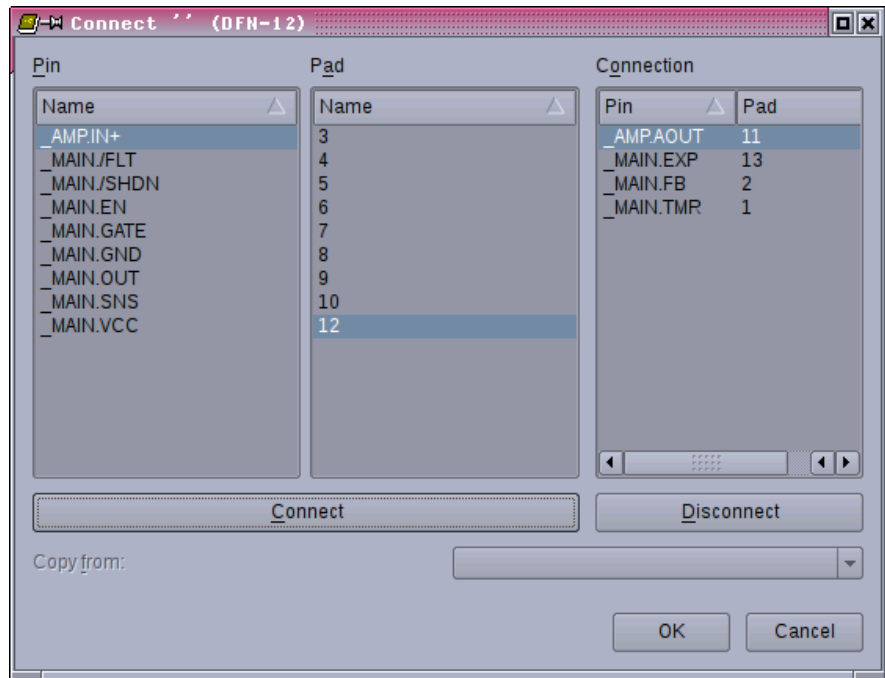

Image 50: Connect Dialog

Once you're done with the connection list, the yellow exclamation mark (below the package) turns to a green check (Image 51).

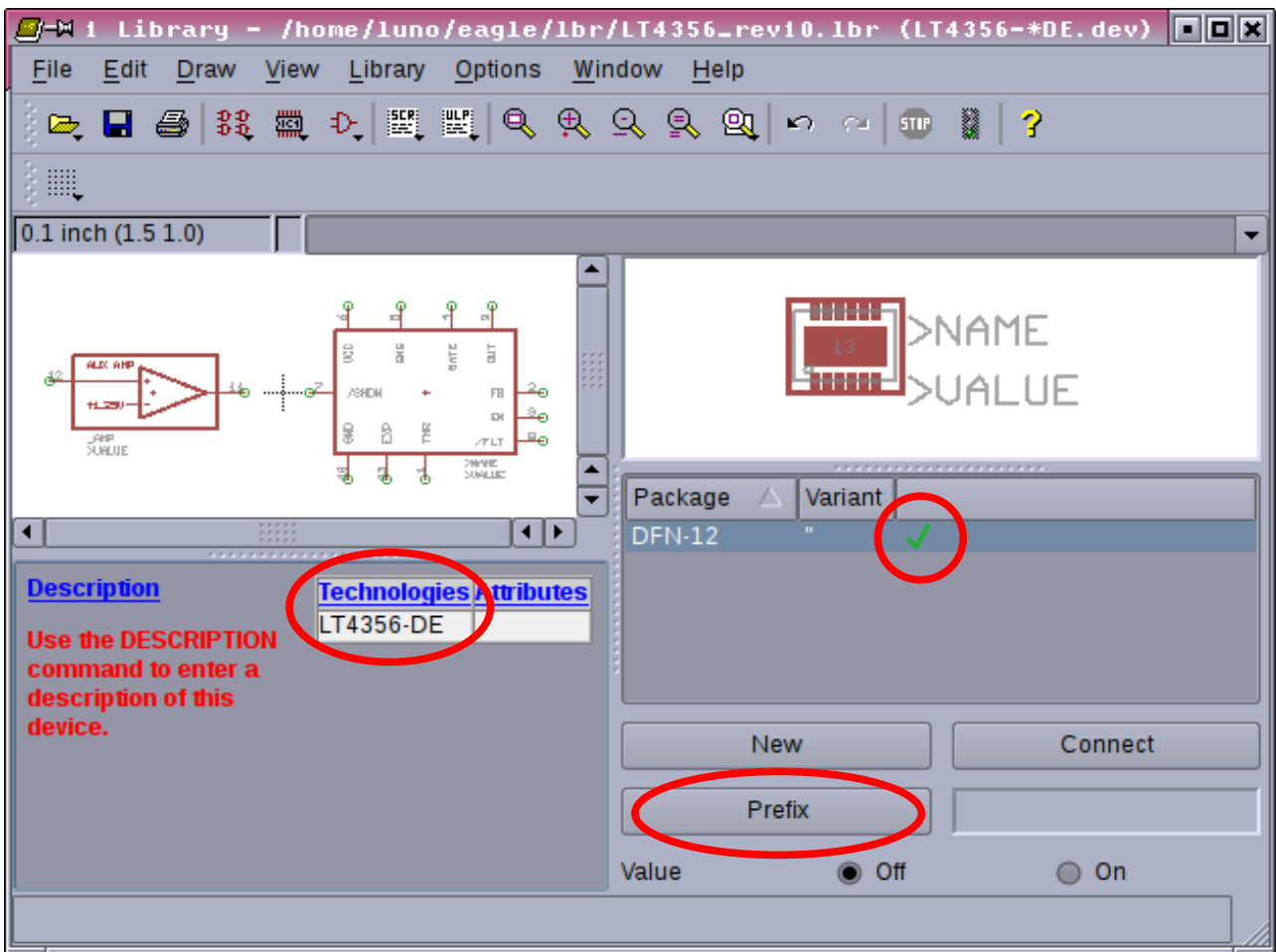

Image 51: Connecting done

2.4.1.4 Prefix

Later in the schematic the *LT4356* should have a name like IC34 or V1701. Click on the prefix button (framed red on Image 51). Enter your preferred prefix here and click OK.

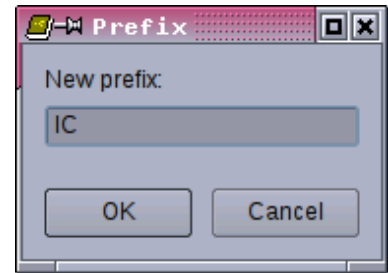

Image 52: Set Prefix

2.4.1.5 Value

It is unlikely that the value of the device needs to be changed later in the schematic. So leave the Value setting as it is on “off” (see Image 51 lower right corner).

2.4.1.6 Technologies

Independent of package or symbols the *LT4356* is manufactured in electrical version #1 and #2. This one digit number has already been cared for by the asterisk (the * character) in the device name *LT4356-*DE*.

- ◆ Click the blue printed word “Technologies” (framed red on Image 51).
- ◆ A box opens that asks for the technology name. Type a “1” in the New-Field and uncheck the default technology as shown on Image 53.

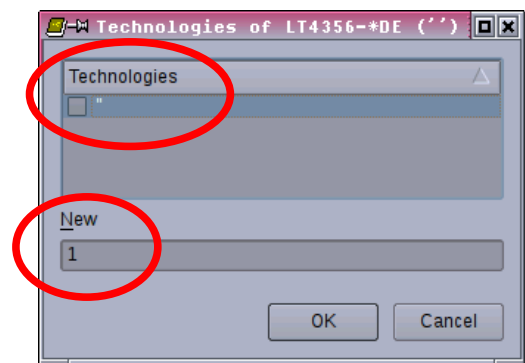

Image 53: Define Technology 1

- ◆ Click OK and create technology “2” as shown in Image 54.
- ◆ Click OK to accept this technology.
- ◆ Exit that box by another click on OK.

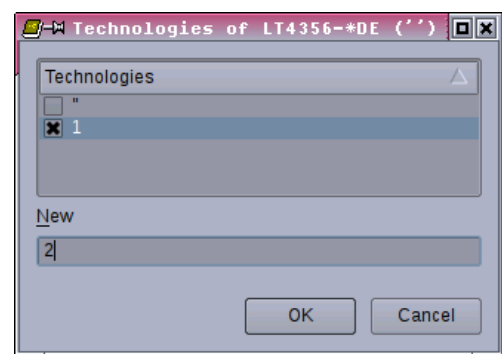

Image 54: Define Technology 2

The technologies overview in your device editor should look as depicted on Image 55 showing the *LT4356-1DE* and the *LT4356-2DE*.

Note the asterisk has been replaced automatically by the numbers 1 and 2 respectively.

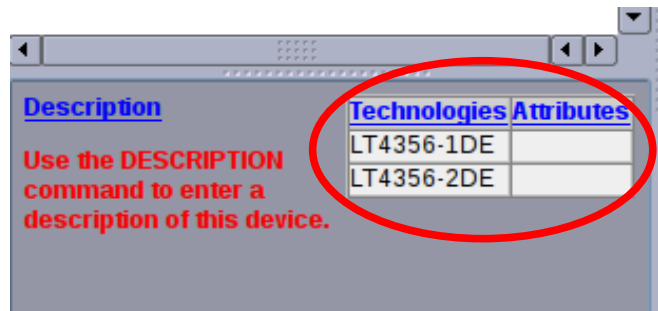

Image 55: Technologies defined

2.4.1.7 Attributes

A look at table Table 1 on page 6 immediately makes clear that lots of further information is needed to exactly specify the *LT4356* like temperature range, lead free or tape&reel shipment. Therefore the attributes tool is made for.

- Click the blue word “Attributes” framed red on Image 55.

The attributes editor box opens where for each technology attributes can be defined.

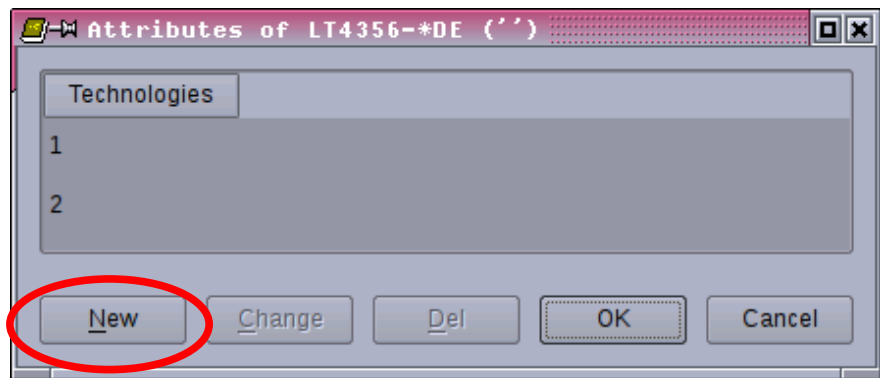

Image 56: Attributes Editor

Let's take the temperature range for example.

- Click “New” and fill the next box as shown on Image 57. Since the primary objective of the *LT4356* are (peaceful) avionics applications the military range is our default value. Both technologies #1 and #2 are available for commercial and industrial temperature range as well. So the value shall not be fixed but variable.

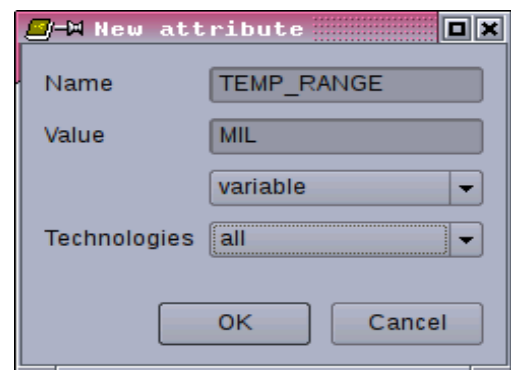

Image 57: New Attribute

- Now click OK and you are taken back to the attributes overview that should look as on Image 58 now.

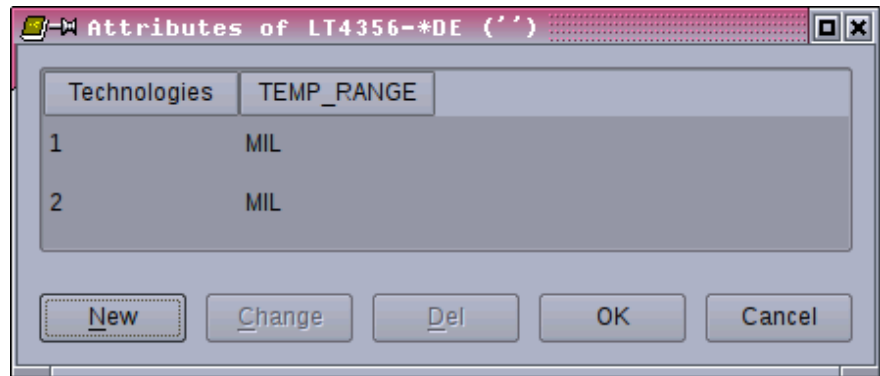

Image 58: Attribute "Temperature Range" defined

Let's assume there are no more attributes to add.

- Click OK and have a look at the device editor that shows the attributes defined so far (Image 59).

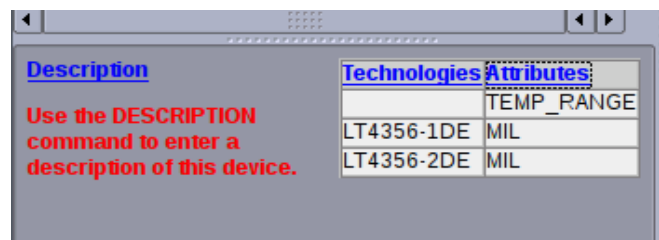

Image 59: Back in the Device Editor

- You may save the library as it is now, close EAGLE down and have a break. Further attributes can be specified any time by click on the blue word "Attributes".
- Reasoning from Table 1 on page 6 the kind of finish and the tape&reel option should be added the same way as the temperature range as shown on Image 60.

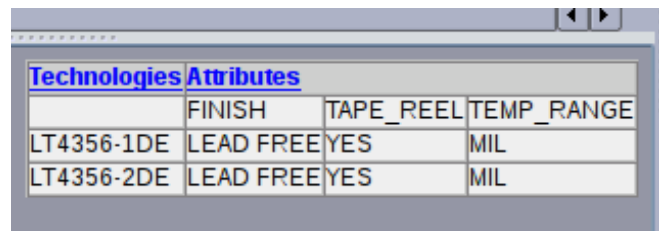

Image 60: Further Attributes defined

An idea is to use the attributes to define a preferred distributor for the device and the order code for that vendor. So all information is handy to order the device quickly or trace down the supply chain.

2.4.1.7.1 Company Internal Part/Device Codes

It is common for companies to have their internal part or device code that applies only for that facility.

- ◆ So click on “Attributes” and fill the box as shown on Image 61 and set the imaginary value “NCC-1701D” to **constant**. It is a constant because within your company the device LT4356-1, DE package, lead free, tape&reel and military temperature range is registered as NCC-1701D.
- ◆ Click OK and see what happens in the attributes overview (Image 62). The newly defined device code appears only in the technology “1” line.

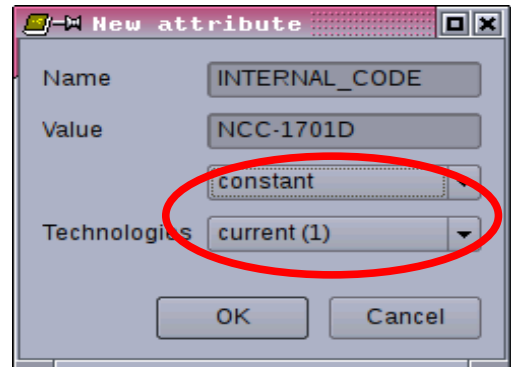

Image 61: Internal Code 1

- ◆ Now click the empty field right below the 1-device code (framed red on Image 62) followed by a click on the “Change” button.

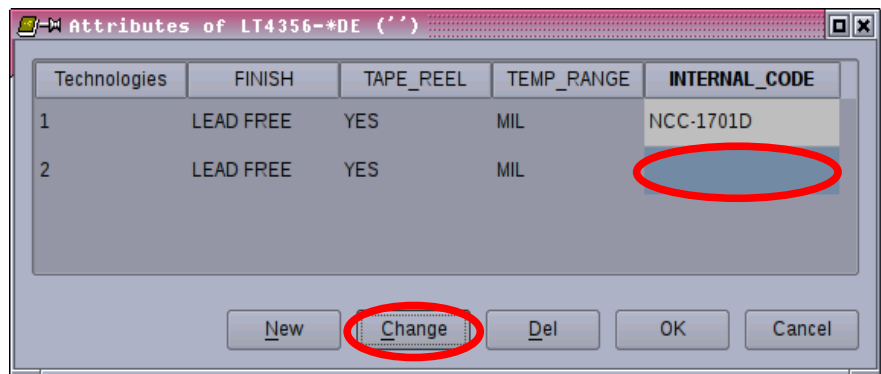

Image 62: Change Internal Code

- ◆ Enter the device code for version “2” in the box that comes up now (Image 63). Call it NCC-1701E for example and make it a constant too.
- ◆ By click on OK you get back to the attributes overview window. There click on OK also and you're back in the device editor.

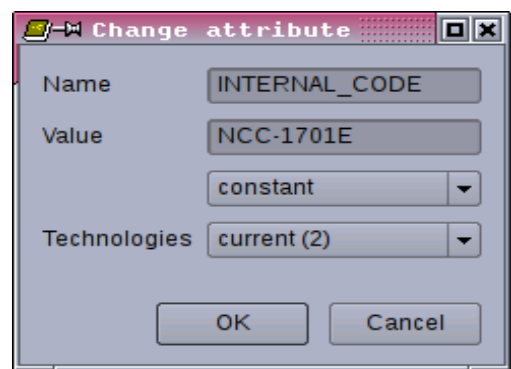
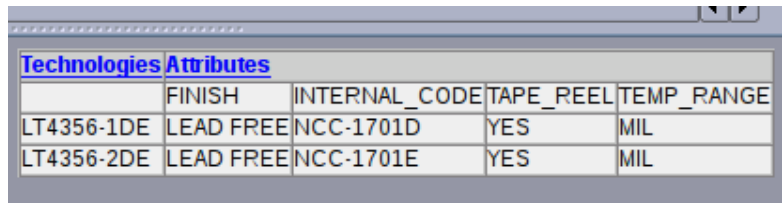

Image 63: Internal Code 2

Your technologies and attributes should look as shown on Image 64.



Technologies	Attributes			
	FINISH	INTERNAL_CODE	TAPE_REEL	TEMP_RANGE
LT4356-1DE	LEAD FREE	NCC-1701D	YES	MIL
LT4356-2DE	LEAD FREE	NCC-1701E	YES	MIL

Image 64: Attributes done

2.4.1.8 Device Description

Finally your device needs some explanation of who created the model and its creation time.

- ◆ Run the command `desc` or click the blue word “Description” left hand of the technologies and attributes overview (see Image 59 page 40). A box opens where you can type some text as shown on Image 65.

Note: Since this text is HTML by nature, the line break (or carriage return) must be written as “`
`”. Just pressing ENTER does not work.

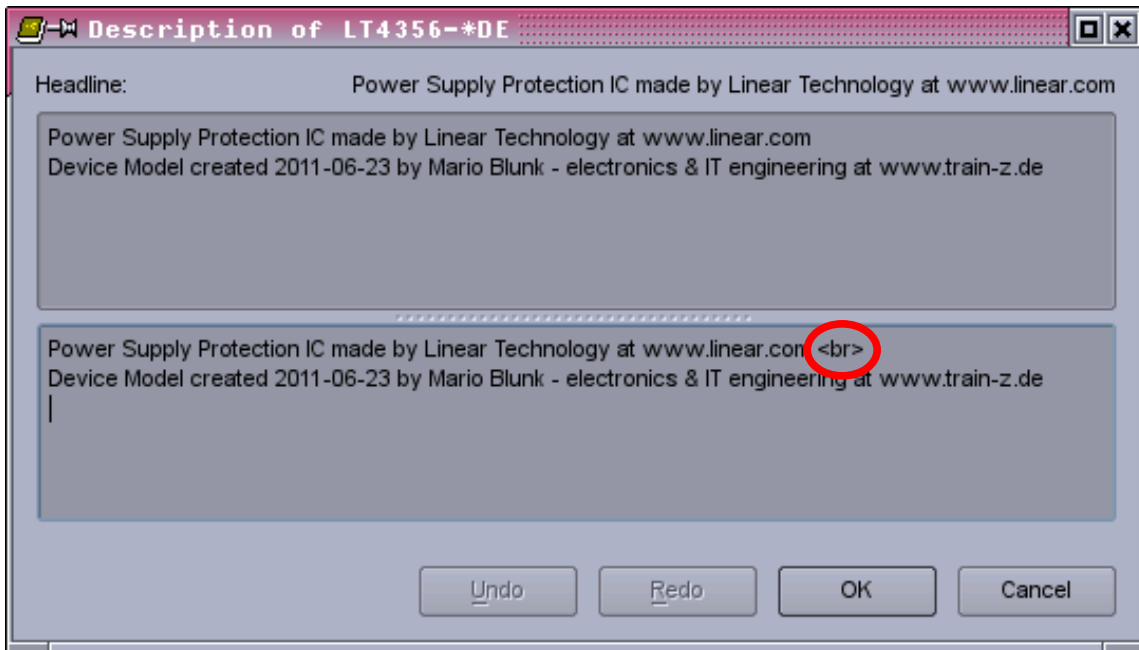

Image 65: Device Description

2.4.1.9 Make the library known to EAGLE

Your device editor window as a whole should look as Image 66.

Now the LT4356-*DE device is ready for use in the schematic and PCB layout !

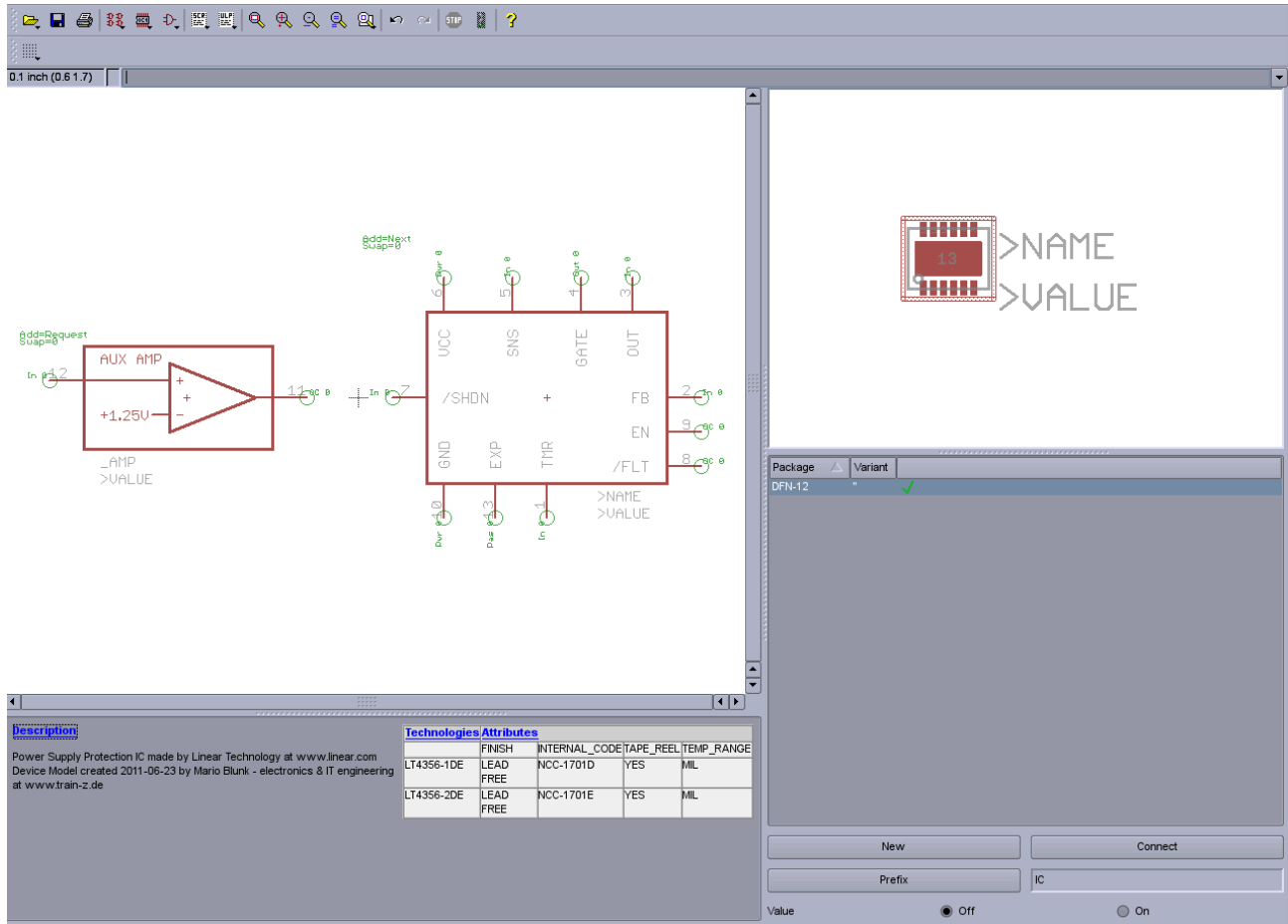

Image 66: DE - Device Setup ready

- ◆ Save your library, close it and **open the schematic.**
- ◆ Tell EAGLE to use that library by running the command `use` and browse to the directory you have saved the library in (Image 67). Then click the "Open" button.

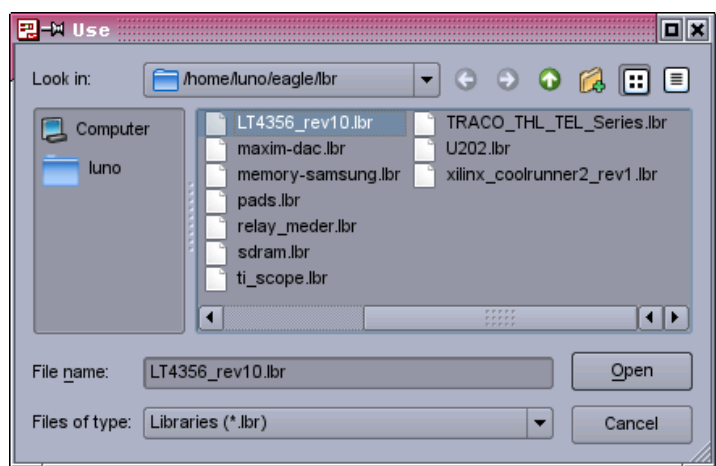

Image 67: Use Library

- ◆ Now you can place the LT4356-*DE in your schematic using the command `add` or the corresponding button in the tool bar.

If everything went correct, the preview the `add` command gives, should look as on Image 68. You see the *LT4356* version #1 and #2 in DE package !

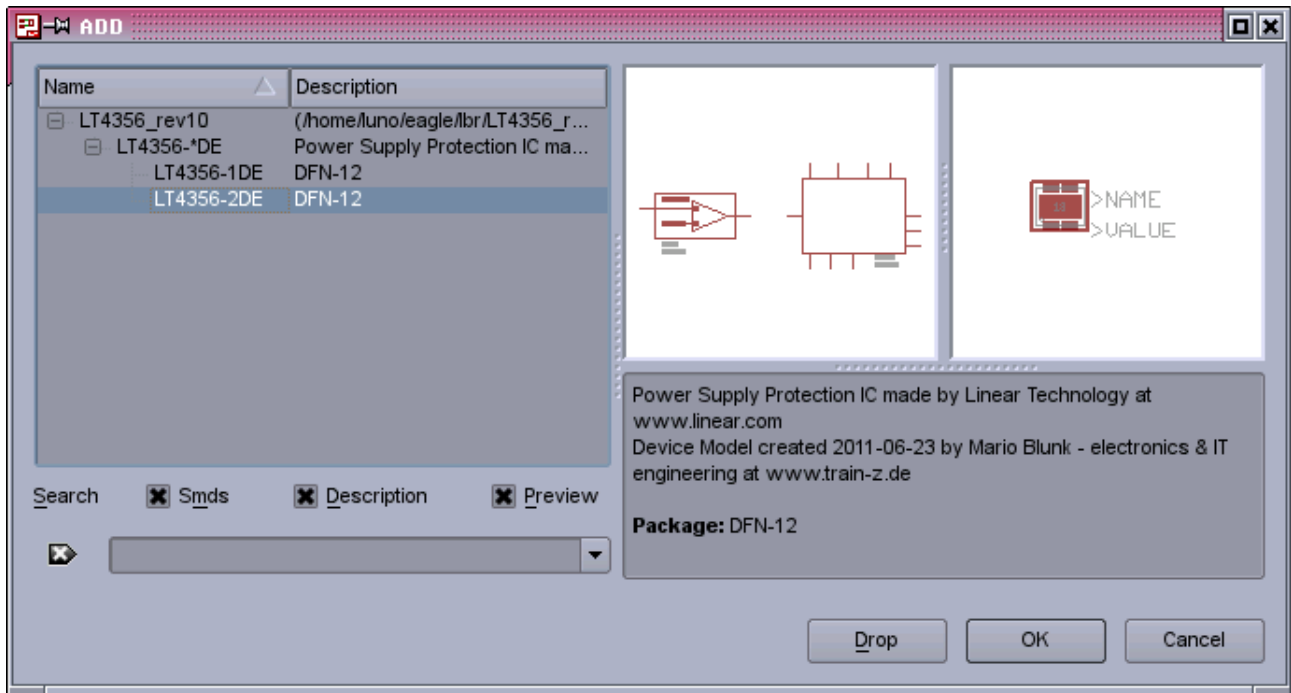

Image 68: Preview when adding the Device

- ◆ Select the version you need and click OK. The LT4356 MAIN symbol is attached to the cursor.
- ◆ Place it in your schematic.
- ◆ In my example here it has gotten the name IC7. Because the AMP symbol is not mandatory it can be fetched any time from the library into the current schematic sheet using for example the command `invoke IC7`.

- ◆ Select the AMP symbol from the box that comes up, click OK and put the AMP symbol down where you need it on the current schematic page (Image 69).

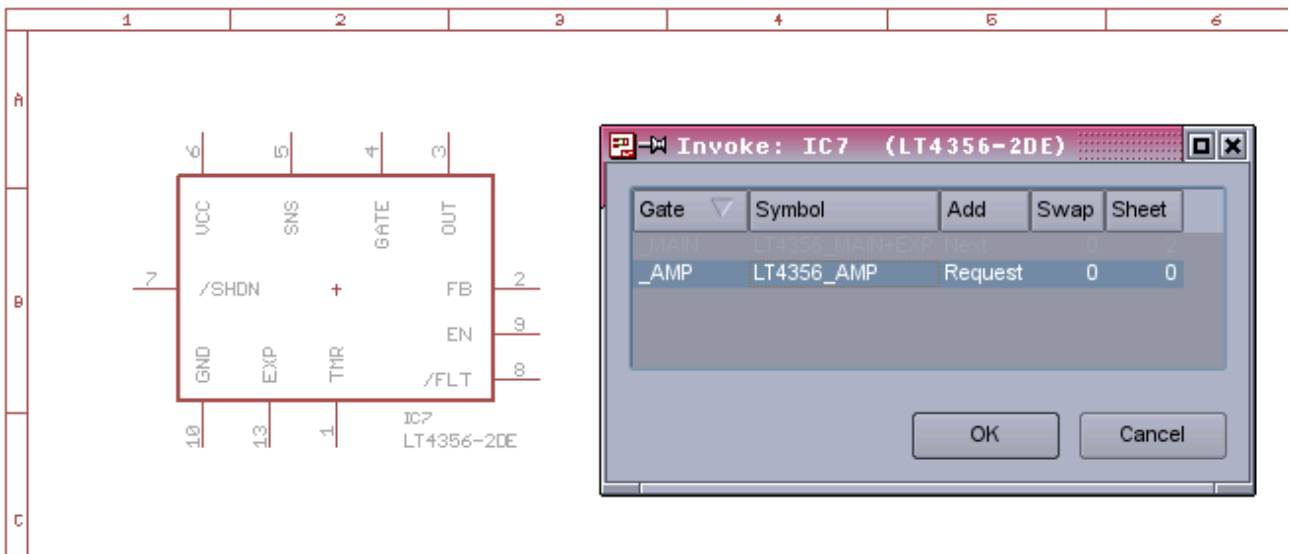

Image 69: Invoke the AMP Symbol

The AMP symbol automatically gets the same name as the MAIN symbol plus an appendix “_AMP” (Image 70). Remember the step when the symbols got named in section 2.4.1.1 .

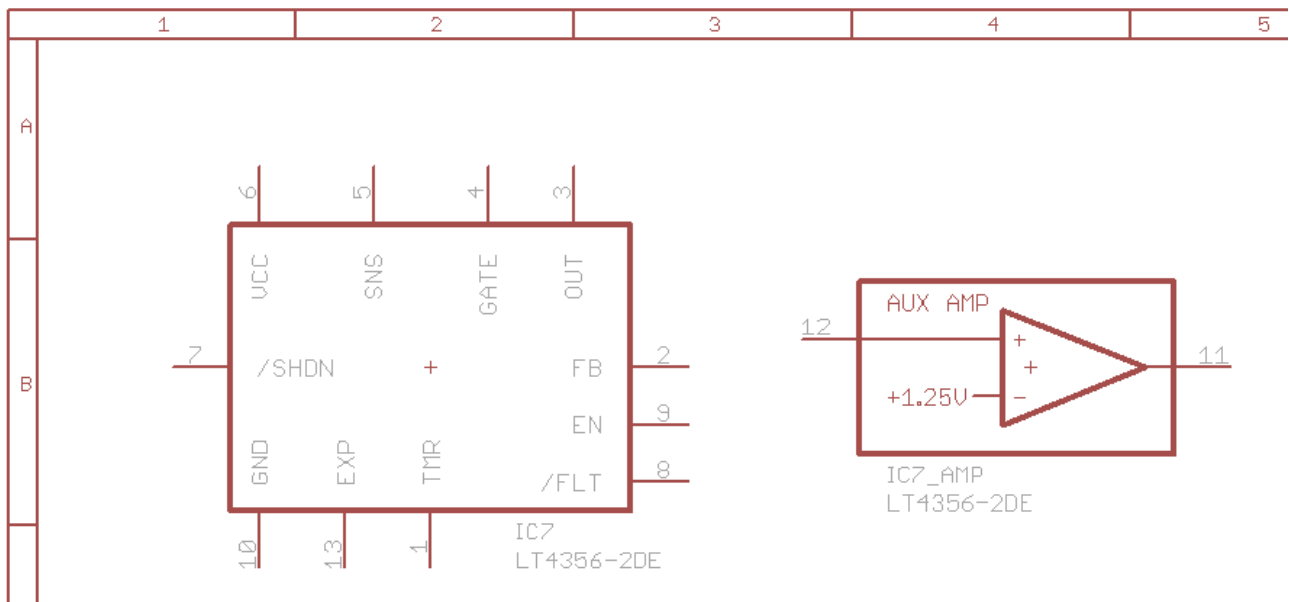

Image 70: The AMP Symbol placed

2.4.2 The MS-Version

The *LT4356* is manufactured with MSOP-10 package lacking the auxiliary amplifier. We need to create a device, lets name it *LT4356-MS*, that incorporates **only** the MAIN symbol **without** the EXP pin.

Remember, the asterisk holds place for the technology #1 or #2. The EXP pin does not exist on the MSOP-10 package (see Figure 3 page 5).

The following steps are described less detailed since we went through the basics already.

- ◆ Create another device *LT4356-MS* (Image 71).
- ◆ Fetch and place the *LT4356_MAIN* symbol using the command `add` and name it *MAIN*.
- ◆ Fetch the MSOP10 package with command `pac`.

Note: You won't need other packages like the DFN12 or the SO16 because the *LT4356* version without auxiliary amplifier exists in the MSOP10 package only.

- ◆ Connect symbol and package pins (command `connect` or the "Connect" button).
- ◆ Set the prefix to "IC".
- ◆ Define Technologies and Attributes.
- ◆ Save the library.

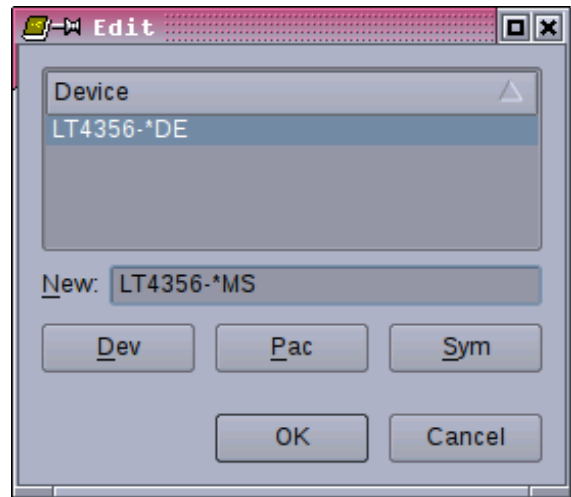

Image 71: Create second Device

Your work should look as shown on Image 72.

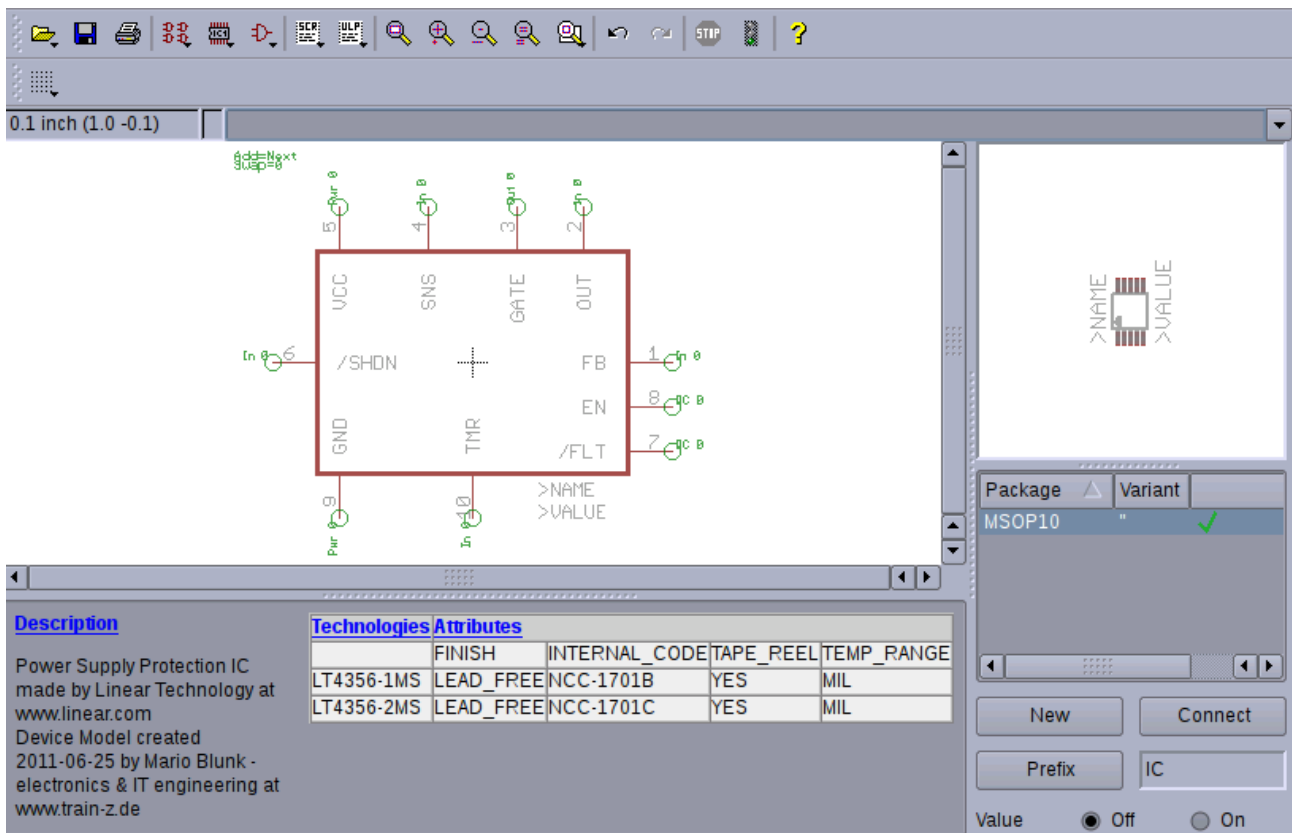

Image 72: MS - Device Setup ready

2.4.3 The SO version

The SO version of the *LT4356* **does** have the auxiliary amplifier built in but does **not** have the EXP pin.

- ◆ So create a third device and name it *LT4356-*SO*. This device is to be assembled with the symbols *LT4356_MAIN* and *LT4356_AMP*. You need the SO16 package only for this version (see Image 73).

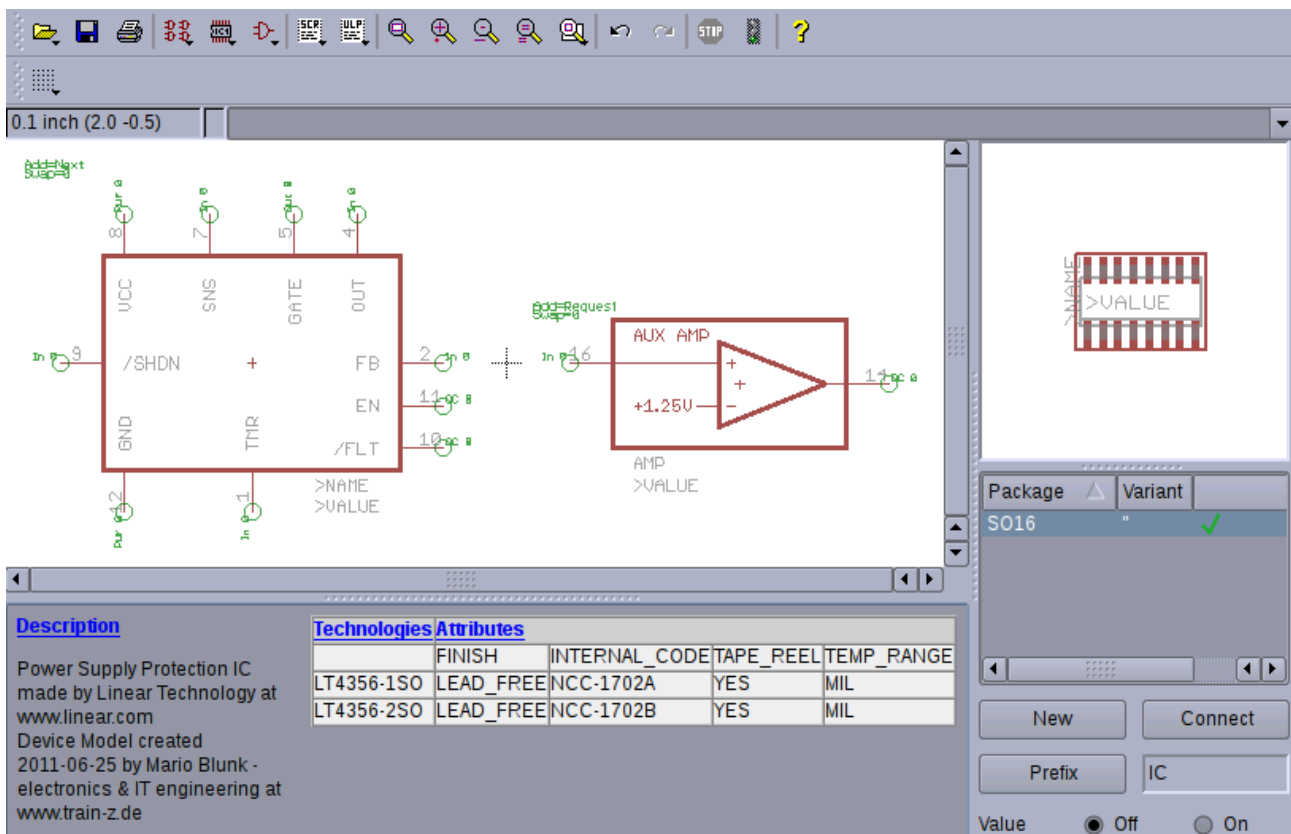

Image 73: S - Device Setup ready

2.5 Library Description

A last action to document your work it's always recommended to leave a few lines that describe the library as a whole.

Since the library `LT4356_rev10.lbr` is solely made for the `LT4356` the description is the same as for the devices.

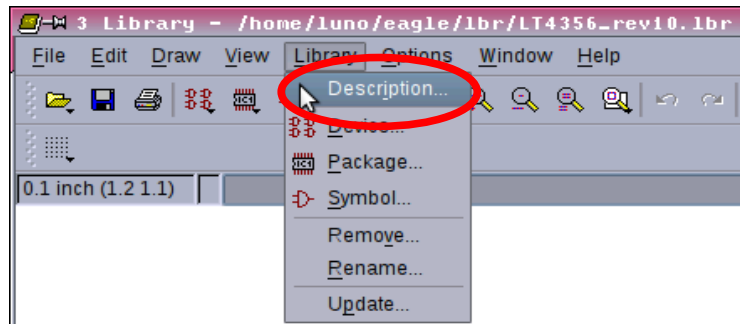

Image 74: Library Description

- ◆ So go to menu *Library/Description* as marked on Image 74 and paste the text we used when describing the devices in the description box next (Image 75).

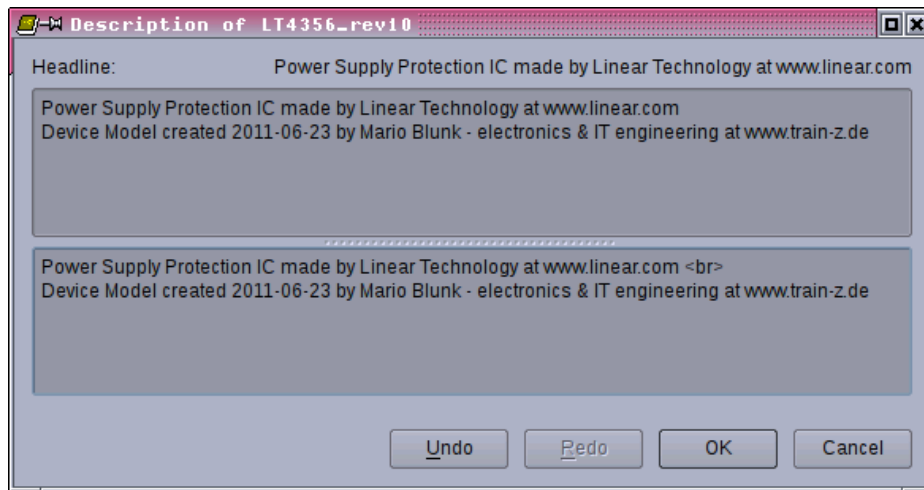

Image 75: Library Description done

2.6 Deleting, Renaming and Copying Symbols, Packages and Devices

There will be situations when an erroneously created symbol, package or device needs to be deleted or renamed.

Important:

Within the library there is **no** menu function like “Save Symbol as ...” !

The save-as function in the menu “File/Save as ...” applies for the **whole** library file (with all its symbols, packages and devices) like your LT4356_rev10.lbr !

2.6.1 Removing

- Go to the menu *Library/Remove* as marked red on Image 76.

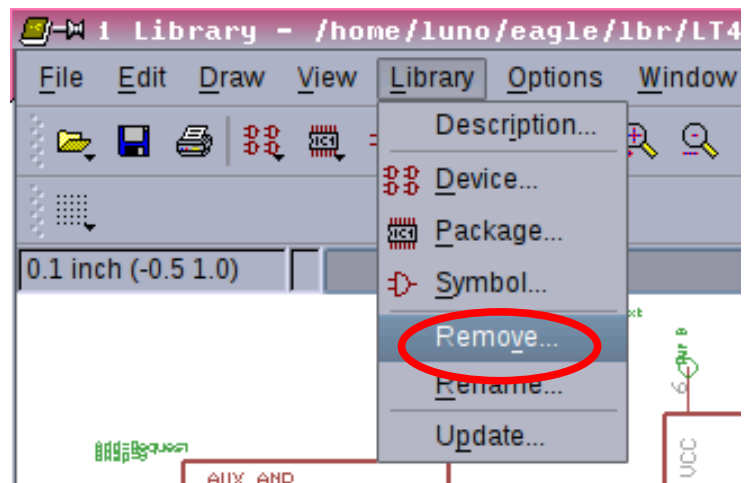

Image 76: Remove Elements

- Type the element you like to remove in the box that comes up. You need to know the exact name of the symbol, package or device as there is no pull-down menu to select.

Don't forget the extension like sym, pac or dev (Image 77) !

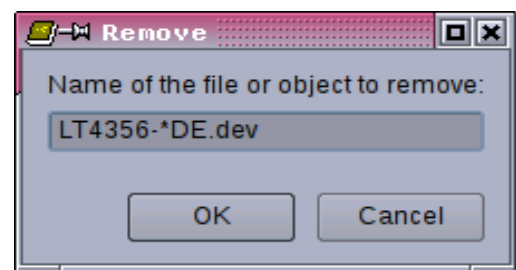

Image 77: Remove Device

Note: A symbol or package already used by a device can not be removed !

Alternatively and probably much faster the command line can be used (Image 78 and Image 79).

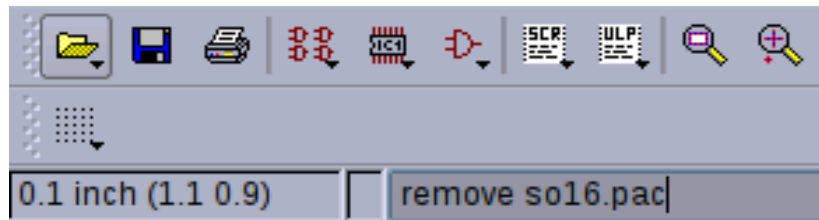

Image 78: Remove Package per Command Line

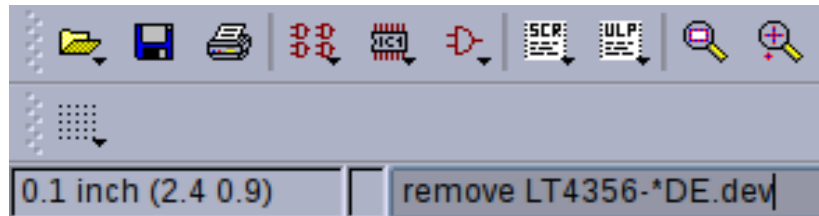

Image 79: Remove Device per Command Line

2.6.2 Renaming

- ◆ First open the symbol, package or device you need to rename.
- ◆ Go to menu entry *Library/Rename*.
- ◆ Type the new name of the element in the box coming up next (Image 81 and Image 82).

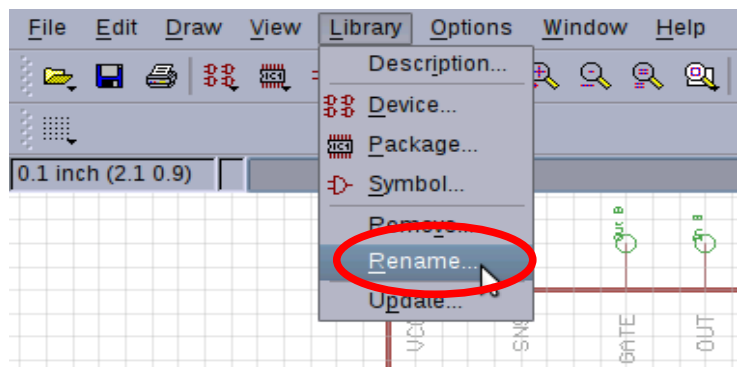

Image 80: Rename Element

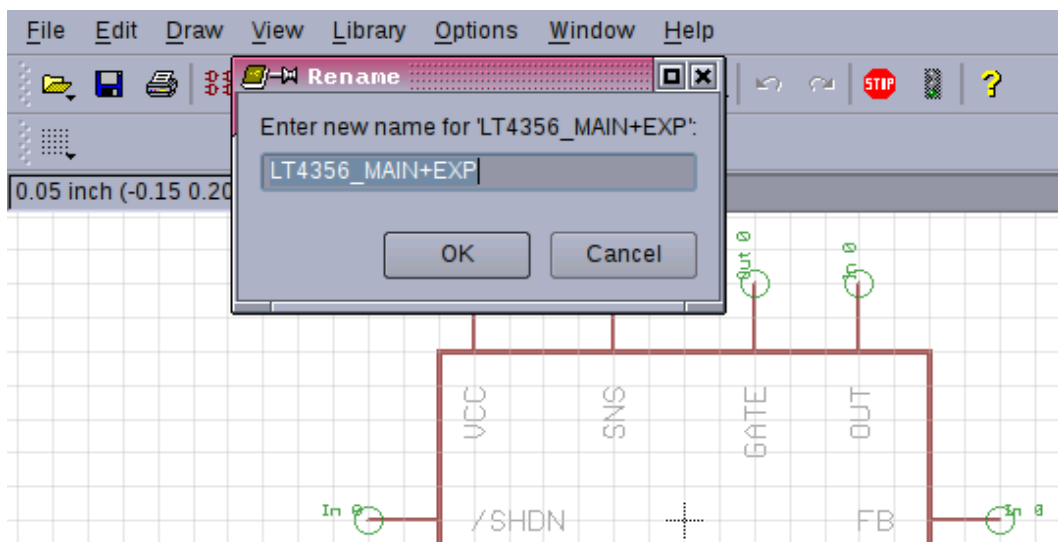

Image 81: Rename Symbol

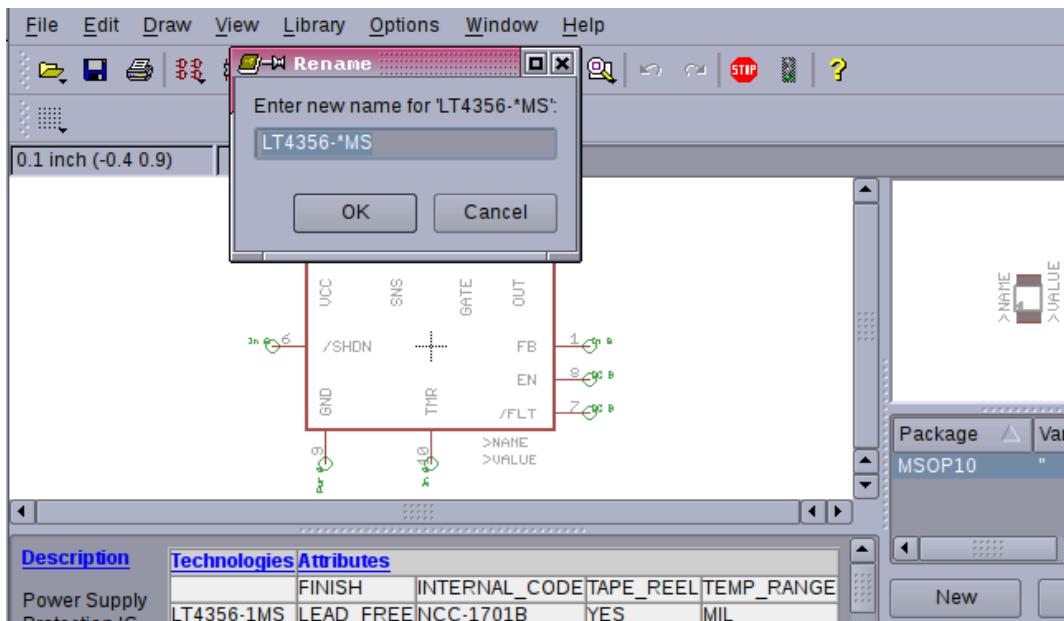

Image 82: Rename Device

2.6.3 Copying

Unfortunately there is no direct way to copy a symbol, package or device directly within the same library. Instead the familiar succession of the commands `group all`, `cut` and `paste` is to be applied.

Remember in section 2.2.3 page 16 we did this when creating the symbol `LT4356_MAIN`. This method also works when copying from one library to another.

3 BOM Exporting

By default *EAGLE* does **not** export attributes into the BOM (Bill of Material) via the menu entry *File/Export/Partlist* .

- ◆ Instead download the ULP (User Language Program) **bom_w_attr_v1.03.ulp** from

ftp://ftp.cadsoft.de/eagle/userfiles/ulp/bom_with_attributes.zip

and execute it with the command `run` . Once launched just follow the menu that comes up (Image 83).

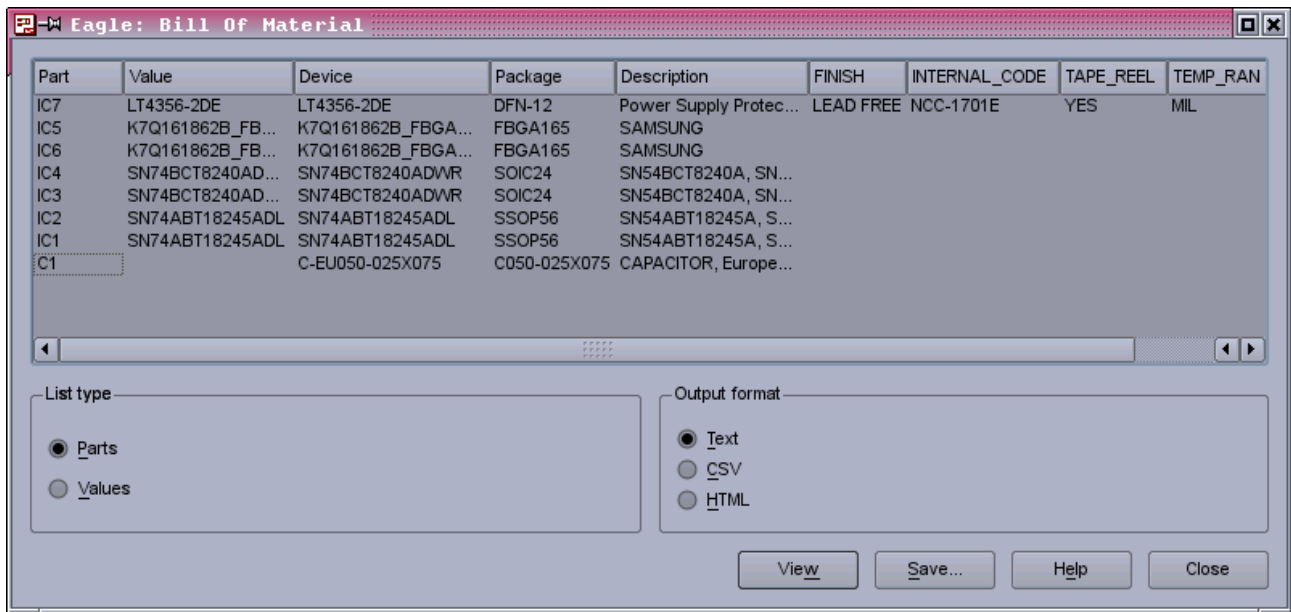
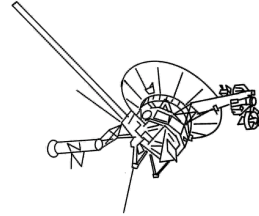

Image 83: Export BOM via ULP

4 Useful Links

I recommend to visit following URLs:

- ◆ *CadSoft EAGLE Training* – a reasonable way to reasonable work at <http://www.train-z.de>
- ◆ Debug SPI, I²C, Boundary Scan/JTAG and other hardware with the *Logic Scanner* at http://www.train-z.de/logic_scanner/index.html



- ◆ *EAGLE* - an affordable and very efficient schematics and layout tool at <http://www.cadsoftusa.com/>



- ◆ An introduction to the *LT4356* by *Steve Munns*, *Linear Technology Corp.* at <http://www.eetimes.com/design/military-aerospace-design/4212950/Power-supply-protection-for-aviation-and-defense-applications>



- ◆ The EAGLE device model *LT4356* can be downloaded here <http://www.train-z.de/eagle/misc/>

5 Disclaimer

This document is believed to be accurate and reliable. I do not assume responsibility for any errors which may appear in this document. I reserve the right to change it at any time without notice, and do not make any commitment to update the information contained herein.

My Boss is a Jewish Carpenter

Mario Blunk - electronics & IT engineering / Buchfinkenweg 5 / 99102 Erfurt / Germany +49 (0) 176 2904 5855 / <http://www.train-z.de>

© 2011 Mario Blunk

Printed in Germany